



**Riduttori  
a vite senza fine**

- RS** - Singolo stadio  
**RA** - Con precoppia  
**RS/RS** - Doppio stadio

- Potenza da 0,06 a 15 kW
- Rapporto di riduzione da 7:1 a 10.000:1
- Coppia uscita da 2.5 a 3020 Nm



**Worm gearboxes**

- RS** - One stage  
**RA** - Helical / worm  
**RS/RS** - Two stage

- Power from 0.06 to 15 kW
- Reduction ratio from 7:1 to 10,000:1
- Output torque from 2.5 to 3020 Nm



**Schneckengetriebe**

- RS** - Einstufige  
**RA** - mit Stirnrad-Vorstufe  
**RS/RS** - Doppelstufige

- Leistungen von 0,06 bis 15 kW
- Untersetzungen von 7:1 bis 10.000:1
- Ausgangsdrehmoment von 2.5 bis 3020 Nm

**RS**



**RA**



**RS/RS**



## RIDUTTORI SERIE RS - RA - RS/RS GEARBOXES SERIES RS - RA - RS/RS SCHNECKENGETRIEBE BAUREIHE RS - RA - RS/RS

### RS - Vite senza fine

I riduttori della serie RS, sono costruiti con carcassa e coperchi in alluminio pressofuso fino alla grandezza RS85 e in ghisa dalla grandezza RS110.

Le coppie indicate nelle tabelle di selezione sono coppie di uscita relative alla grandezza considerata e le potenze sono riferite a 1440 min<sup>-1</sup>.

I paraolio entrata in Viton, montati su richiesta, rendono possibili senza problemi gli azionamenti con motori a 2 poli o motori c.c. a 3000 min<sup>-1</sup>.

I riduttori vengono spediti già riempiti con lubrificante sintetico a lunga durata (senza tappi) nei quantitativi indicati a pag 7 validi per qualunque posizione di funzionamento.

I valori delle tabelle di selezione sono intesi per fattore di servizio FS1.0, cioè con funzionamento di 8-10 ore al giorno, con carico uniforme, avviamenti inferiori a 6 all'ora e temperatura ambiente fra 15 e 35 °C.

### RA - Vite senza fine con precoppia

I riduttori della serie RA, composti da un riduttore FXA indipendente a una coppia di ingranaggi montato su un riduttore standard del tipo FRS, forniscono una maggior coppia di uscita ed un più elevato rendimento degli equivalenti rapporti del tipo RS.

### RS- Worm gears

The worm gearboxes, RS series, are manufactured with die cast housings and covers in aluminium up to the size RS85 and cast iron from the size RS110.

Torques listed in selection tables are output torque values for the specific size, and motor powers are always referred to 1440 r.p.m.

Input Viton oilseals, fitted on demand, allow free-trouble operation with 2-pole standard ac motors or 3000 rpm dc motors.

Gearboxes are delivered filled with synthetic long-life oil (without plugs), in quantities as recommended on page 7, and valid for all mounting positions.

Selection table data are intended for service factor SF1.0 i.e. 8-10 running hours per day, uniform load, less than 6 start/stops per hour, and room temperature ranging from 15 to 35 °C.

### RA - Helical worm gears

The gearboxes, RA series, made up of an independent single stage helical gearbox FXA fitted to a standard FRS gearbox, allow greater output torques and higher efficiency than the FRS gearbox with equivalent ratios.

### RS-Schneckengetriebe

Die Getriebe der Serie RS, haben bis zur Baugröße RS85 Gehäuse und Deckel aus Aluminium-Druckguß und aus Guß bei Baugröße RS110, Die in den Auswahltabellen genannten Drehmomente sind jeweils die Ausgangsdrehmomente der entsprechenden Baugröße, und die Leistungen beziehen sich auf eine Nenndrehzahl von 1440 min<sup>-1</sup>. Wellendichtringe aus Viton, auf Anfrage auf der Eingangsseite montiert, ermöglichen einen problemlosen Einsatz von 2-poligen Motoren oder Gleichstrommotoren bis 3000 1/min im Dauerbetrieb. Die Getriebe werden ausgeliefert mit Langzeitschmiermittelfüllung (ohne zusätzliche Verschlussschrauben) und sind für alle Montagepositionen ausreichend befüllt. Die Tabellenwerte berücksichtigen einen Betriebsfaktor von FS 1.0, d.h. Betrieb 8-10 Stunden/Tag, gleichmäßige Belastung, weniger als 6 Schaltvorgängen (Start und Halt) je Stunde und Umgebungstemperaturen zwischen 15 und 35 °C.

### RA - Schneckengetriebe mit Stirnradvorstufe

Die Getriebe der Serie RA, bestehen aus einer Kombination eines separaten einstufigen Stirnradgetriebes FXA, mit einem Standard FRS Schneckengetriebe und erlauben ein größeres Abtriebsdrehmoment bei besserem Wirkungsgrad als einstufige RS- Schneckengetriebe mit gleicher Übersetzung.

	SPECIFICHE GENERALI	GENERAL SPECIFICATIONS	ALLGEMEINE EIGENSCHAFTEN
Gamma Range Bereich	9 grandezze 55 rapporti di riduzione 3020 Nm coppia uscita max	9 sizes 55 reduction ratios 3020 Nm max. output torque	9 Baugrößen 55 Übersetzungen 3020 Nm max. Abtriebsmoment
Dimensionamento Sizing Auslegung	Secondo BS721. Vita media 15.000 ore con fattore di servizio SF1	According to BS721. 15,000 hrs average lifetime with service factor SF1	Entsprechend BS721 15T Stunden Lebensdauer für Verzahnung und Lagerung bei einem Bfaktor SF1
Carcassa, Coperchi Housing, Covers Gehäuse, Flansche	Pressofusione in alluminio AISi12Cu2Fe fino RS85 e ghisa G25 da RS110.	Pressure die cast aluminium AISi12Cu2Fe till size RS85 and cast iron from RS110.	Aluminium-Druckguss AISi12Cu2Fe. bis Größe RS85 und G25 für RS110.
Parti dentate Toothed parts Verzahnung	Viti in acciaio 20MnCr5 cmt / tmp. con profilo ZI rettificato. Ruote in bronzo CuSn12 su mozzo in ghisa.	Worms of steel 20MnCr5 CH and tooth profile ZI ground. Wheels of bronze CuSn12 on CI hub.	Stahl 20MnCr5 einatzgehärtet. Zahnprofil geschliffen. Schneckenrad in Bronze CuSn12 HW Roheisen
Alberi & Linguetta Shafts & Keys Wellen	Acciaio C43 Alberi h6 - Fori E8 Linguetta secondo DIN6885 B1	Steel C43 Shafts h6 - Bores E8 Keys according to DIN6885 B1	Stahl C43 Wellen h6 – Bohrungen E8 Passfedern nach DIN6885 B1
Cuscinetti Bearings Lagerung	Sfere o rulli secondo grandezza e specifiche tecniche	Ball- or roller-types according to sizes and technical requirements	Kugel- oder Rollenlager entsprechend den technischen Vorschriften
Paraolio Oilseals Dichtungen	Tipo NB - nitril-butadiene con secondo labbro parapolvere secondo DIN 3760	Type NB - nitril-butadiene with additional anti-dust lip according to DIN 3760	Typ NB – Nitril-Butadien mit zusätzlicher Staublippe entsprechend DIN 3760
Lubrificante Lubricant Schmierung	Olio sintetico a lunga durata Gradazione ISO VG 320	Synthetic long-life oil Grade ISO VG 320	Synthetisches Getriebeöl ISO VG 320 als Langzeit-Füllung
Verniciatura a forno Baking painting Gehäuselackierung	RS110-150: vernice a polveri epossidiche, colore std RAL 7012. RS28-85: alluminio naturale.	RS110-150: epoxy powder paint, std colour RAL 7012. RS28-85: real aluminium.	RS110-150: Epoxydpulverfarbe Standardfarbton RAL 7012 RS28-85: Alluminium natural

## RIDUTTORI SERIE RS - RA - RS/RS GEARBOXES SERIES RS - RA - RS/RS SCHNECKENGETRIEBE BAUREIHE RS - RA - RS/RS

### RS/RS - Vite senza fine - doppio stadio

I riduttori della serie RS/RS sono composti da due riduttori della serie RS e forniscono una ampia scelta di elevati rapporti a completamento della serie RA per ottenere rotazioni alle più basse velocità.

### AS, AD - Albero di uscita

Tutti i tipi di riduttori sono normalmente costruiti con albero uscita cavo e, a richiesta, può essere fornito l'albero lento sporgente, semplice AS o doppio AD, in acciaio C43. Su richiesta è disponibile una protezione di sicurezza ASC dell'estremità non utilizzata dell'albero AS.

### BR, BRV - Braccio di reazione

I riduttori standard sono forniti normalmente su entrambi i lati con coperchi che permettono il fissaggio del braccio di reazione quando essi debbono funzionare come riduttori pendolari. Il braccio reazione BR o BRV (con boccola antivibrante in Vulkollan) è costruito in lamiera a elevato spessore e zincato bianco.

### TLI/TLE - Limitatore di coppia

Il dispositivo limitatore di coppia - TLI realizzato all'interno del riduttore e TLE installabile esternamente - permette la regolazione della coppia trasmissibile, la protezione del motoriduttore in caso di ostacolo accidentale, il semplice sblocco del sistema e la manovra manuale in caso di mancanza di corrente. Il valore della coppia di slittamento, tarato in fabbrica, è regolabile in diminuzione dal valore di coppia massima a zero e la rotazione dell'albero di uscita riprende quando la coppia ridiscende al disotto del valore prefissato. Le quantità d'olio del limitatore TLI sono riportate a pagina 26.

### SL - Limitatore di giri

Il dispositivo SL arresta - per mezzo di fine corsa interni - il funzionamento del motoriduttore dopo un tempo prefissato. La filettatura standard permette circa 40 giri dell'albero di uscita. L'escursione dei fine corsa è regolabile e il tempo di funzionamento varia a seconda del rapporto utilizzato da 12 secondi minimo a 170 secondi massimo.

### Motori elettrici

I motori elettrici sono forniti con voltaggio trifase 230/400V ( $\pm 10\%$ ) e monofase 230V, frequenza 50Hz, 4 poli, classe di isolamento F con temperatura ambiente di 40°C, grado di protezione IP 55.

A richiesta, motori con caratteristiche diverse, monofasi ad alta coppia di spunto, autofrenanti, a doppia polarità, per azionamento con inverter separato o a bordo.

La morsettiere viene intesa posizionata come standard verso il basso per i tipi a stadio singolo o con precoppia, comunque e nel caso di doppio stadio riferirsi a pag. 6.

### RS/RS - Two stage worm gears

The gearboxes, RS/RS series, are made up of two gearboxes RS and offer a full selection of high reduction ratios to obtain the very low output speeds.

### AS, AD - Output shafts

All the gearboxes are manufactured with hollow output shaft as standard version and, optionally, a single AS or double AD solid output shaft - made of steel C43 - can be supplied.

A ASC safety shield for the opposite side of a single output shaft AS, is available on demand.

### BR, BRV - Torque arms

Standard gearboxes are supplied normally with covers on each side allowing torque arm fixing when gearboxes have to operate as shaft mounted units.

The torque arm BR or BRV (with Vulkollan vibration-damping) is made of extra thick plate and white galvanized.

### TLI/TLE - Torque limiters

The torque limiter and safeguard device - TLI built-in inside the gearbox and TLE fitted outside - allows easy torque adjustments, full gearbox safeguard against unexpected overload conditions, simple hand release, and manual operation in case of power supply failure.

Slipping torque, factory preset, can be adjusted from the maximum pre-set torque down to zero, and shaft rotation restarts automatically as soon as torque value is lower than the pre-set value.

Oil quantity of torque limiter TLI are listed at page 26.

### SL - Travel limiters

The SL travel limiter device stops - by means of built-in limit switches - the gearbox after a given operation time.

Standard thread allows approx. 40 turns of the output shaft. Limit switch travel is adjustable and operation time varies upon the used reduction ratio from min. 12 to max. 170 seconds.

### Electric motors

The electric motors are supplied with voltage 230/400V ( $\pm 10\%$ ) three-phase and 230V single-phase, frequency 50 Hz, 4 poles, temperature class F at ambient temperature 40 Celsius, protection IP55.

On request, motors according to different specifications, high starting torque single-phase, brake-motors, dual-speed motors, for separate or on board inverter drive.

The terminal box is located downwards as standard in worm or helical/worm gear boxes, however and in case of two-stage types refer at page 6.

### RS/RS - Doppelstufige Schneckengetriebe

Die Getriebe der Serie RS/RS sind eine Kombination zweier Schneckengetriebe der RS Baureihe und bieten eine weitgehende Auswahlmöglichkeit an hohen Untersetzungen und somit sehr kleinen Abtriebsdrehzahlen.

### AS, AD - Ausgangswelle

Alle Getriebe werden in Hohlwellen-Ausführung hergestellt. Als Zubehör können Einsteckwellen in der Version AS als einseitige Welle oder AD als beidseitige Welle geliefert werden. Diese Einsteckwellen sind aus C43 Stahl gefertigt. Auf Anfrage ist auch ein Wellenschutz ASC als Abdeckung eines Hohlwellenendes lieferbar.

### BR, BRV - Drehmomentstütze

Die Getriebe werden normalerweise mit Deckeln auf beiden Abtriebsseiten geliefert, die Bohrungen und Zentrierung für die Befestigung einer Drehmomentstütze besitzen, wenn das Getriebe in der Aufsteckversion eingesetzt wird. Die Drehmomentstütze BR oder BRV (mit Dämpfungsbuchse aus Vulkollan) ist aus starkem verzinktem Blech hergestellt.

### TLI/TLE - Drehmomentbegrenzer

Die TL Einrichtung ermöglicht die Einstellung der übertragbaren Drehmomente, die Absicherung vom Getriebe gegen Spitzenbelastungen, die einfache Ausschaltung der Antriebseinheit und die manuelle Bedienung im Falle eines Stromausfalles. Das Rutschmoment ist vom max Einstellmoment bis zum Nullwert einstellbar und die Drehbewegung der Abtriebswelle setzt wieder ein, sobald das Drehmoment wieder kleiner als das eingestellte Moment wird. Ölmenge: Seite 26

### SL - Drehzahlbegrenzer

Die SL-Einrichtung stoppt, mittels eingebauten Wegschalter, das Getriebe nach einer bestimmten Zeit. Die Standard Gewindegänge, ermöglichen ca. 40 Umdrehungen der Ausgangswelle. Die Wegschalter sind einstellbar und die Betriebszeit ist, abhängig von der Untersetzung, zwischen min. 12" bis max 170".

### Elektromotoren

Als Elektromotoren kommen Dreiphasenmotoren mit 230/400 V ( $\pm 10\%$ ) und Einphasenmotoren mit 230 V, 50 Hz, 4-polig, Isolationsklasse F bei 40°C Umgebungstemperatur in Schutzart IP 55 zum Einsatz. Auf Anfrage sind auch Motoren in Sonderausführungen lieferbar, ebenso wie Bremsmotoren, Einphasenmotoren mit hohem Anlaufmoment, polumschaltbare Motoren als auch Motoren mit separatem oder integriertem Umrichter. Als Standard befindet sich der Klemmkasten auf der rechten Seite bei Blick auf die Eingangsseite des Getriebes (bei Doppelschneckengetrieben bei Blick auf die erste Getriebestufe).

DESIGNAZIONE DEL RIDUTTORE						GEARBOX DESIGNATION	BEZEICHNUNG GETRIEBE	
<b>F</b>	<b>RS</b>	<b>[../]</b>	<b>40</b>	<b>B3</b>	<b>28</b>	<b>IEC71</b>	<b>B14</b>	<b>(OPS, OPP)</b>
<p>OPS= Opzioni standard pag.26 - <i>Standard options page 26</i> - Standard Optionen Seite 26</p> <p>OPP= Opzioni piè pagina - <i>Options at the foot of the page</i> - Optionen siehe Seitenende</p> <p>B5, B14 = Forma motore - <i>Motor form</i> - Motorbauform</p> <p>Grandezza motore elettrico - <i>Electric motor frame</i> - Motorbaugröße</p> <p>Rapporto di riduzione - <i>Reduction ratio</i> - Untersetzungsverhältnis</p> <p>Forma costruttiva - <i>Mounting form</i> - Montageposition</p> <p>(RS = S, I, D, FL, PC) / (RA = 10, 11, 12, 13) / (RS/RS = 11, 12, 13, 14, 15, 16, 17, 18)</p> <p>28, 40, 50, 60, 70, 85, 110, 130, 150 = Grandezza riduttore RS - <i>Gearbox size RS</i> - Baugröße RS</p> <p>63/, 71/, 80/ = Grandezza precoppia RA - <i>RA Helical stage size</i> - Baugröße Vorstufe RA</p> <p>28/, 40/, 50/... = Grandezza 1° riduttore RS/RS - <i>1st RS/RS gearbox size</i> - Baugröße Getriebe 1. RS/RS</p> <p>RS, RA, RS/RS = Tipo riduttore - <i>Gearbox type</i> - Getriebetyp</p>								
M = Motoriduttore	- Geared motor	- Getriebemotor						
F = Flangia entrata IEC	- IEC input flange	- Eingangsflansch IEC						
S = Senza flangia IEC	- Without IEC input flange	- Ohne Flansch IEC						
... = Albero entrata sporgente	- Free input shaft	- freie Eingangswelle						

DESIGNAZIONE DEL MOTORE						MOTORX DESIGNATION	BEZEICHNUNG MOTOR	
<b>MT</b>	<b>0.37kW</b>	<b>71B</b>	<b>4</b>	<b>B14</b>	<b>230/400/50</b>	<b>IP55</b>	<b>F X1</b>	
<p>Posizione morsetti - <i>Terminal box position</i> - Klemmenkastenlage</p> <p>Cl. F (std) = Classe isolamento - <i>Insulation class</i> - Isolationsklasse</p> <p>IP55 (std) = Grado protezione - <i>Protection class</i> - Schutzart</p> <p>Tensione/frequenza - <i>Voltage/frequency</i> - Spannung/Frequenz</p> <p>Forma costruttiva - <i>Mounting</i> - Bauform</p> <p>Numero poli - <i>Number of poles</i> - Polzahl</p> <p>Grandezza IEC motore - <i>IEC motor size</i> - Baugröße Motor</p> <p>Potenza motore - <i>Motor power</i> - Leistung Motor</p>								
MT = Motore trifase	- Three-phase motor	- Dreiphasen-Motor						
MM = Motore monofase	- Single-phase motor	- Einphasen-Motor						
MA = Motore autofrenante	- Brake motor	- Bremsmotor						

OPZIONI OPP	OPTIONS OPP	OPTIONEN OPP
L'allestimento standard, ove non diversamente richiesto, è montato sul lato destro visto dall'entrata.	Standard fitting side, unless otherwise requested, is the right side of the gearbox when seen from the input side.	Die Standardausführung, wenn nicht gesondert angefragt, wird auf die rechte Seite, vom Eingang her betrachtet, montiert.
ACØ - Albero cavo non std ø..	ACØ - Not std hollow shaft ø..	ACØ - Sonderhohlwelle ø..
CS - Cuscinetti uscita non std	CS - Not std output bearings	CS - Sonderlager Ausgang
FL - Flangia uscita FL aggiuntiva	FL - Additional output flange FL	FL - zusätzlicher FL Ausgangsflansch
GRI - Gioco ridotto dentatura	GRI - Reduced gearing backlash	GRI - spielarme Verzahnung
GRM - Gioco ridotto montaggio	GRM - Reduced end play	GRM - spielarme Montage
LNS - Lubrificazione non std	LNS - Not std lubrication	LNS - Sonderschmierung
VB - Vite bisporgente	VB - NDE wormshaft extension	VB - Schneckenwelle beidseitig

POSIZIONI DI MONTAGGIO  
STANDARD MOUNTING POSITIONS  
MONTAGEPOSITION

## RS , RA , RS/RS

Uscita - Output - Ausgang

S ( SA )	I ( IA )	D ( DA )	PC - PC	FL ( FA,FB ) & ( PA,PB )	
<b>B3 (std)</b>	<b>B3 (std)</b>	<b>B3 (std)</b>	<b>B5 (std)</b>	<b>B5 (std)</b>	<b>B5i</b>
<b>V5</b>	<b>V5</b>	<b>V5</b>	<b>B5</b>	<b>B5a</b>	<b>B5ai</b>
<b>B8</b>	<b>B8</b>	<b>B8</b>	<b>B5</b>	<b>B5b</b>	<b>B5bi</b>
<b>V6</b>	<b>V6</b>	<b>V6</b>	<b>B5</b>	<b>B5c</b>	<b>B5ci</b>
<b>B6</b>	<b>B6</b>	<b>B6</b>	<b>V1</b>	<b>V1</b>	<b>V1i</b>
<b>B7</b>	<b>B7</b>	<b>B7</b>	<b>V3</b>	<b>V3</b>	<b>V3i</b>

## RA

Entrata - Input - Eingang

<b>10 (std)</b>	<b>11</b>	<b>12</b>	<b>13</b>		
-----------------	-----------	-----------	-----------	--	--

POSIZIONI DI MONTAGGIO  
STANDARD MOUNTING POSITIONS  
MONTAGEPOSITION

## RS/RS

Uscita - Output - Ausgang

	<b>S</b> ( SA )	<b>I</b> ( IA )	<b>D</b> ( DA )	<b>PC</b> ( PA, PB )	<b>FL</b> ( FA, FB )
<b>11</b>					
<b>12</b>					
<b>13</b>					
<b>14</b>					
<b>15</b>					
<b>16</b>					
<b>17</b>					
<b>18</b>					

FATTORI DI SERVIZIO - PESI & LUBRIFICANTI  
 SERVICE FACTORS - WEIGHTS & LUBRICANTS  
 BETRIEBSFAKTOREN - GEWICHTE U. SCHMIERMITTEL - EINGANGSKRÄFTE

FATTORI DI SERVIZIO  
 SERVICE FACTORS  
 BETRIEBSFAKTOREN

F <sub>1</sub>	a	b	c	F <sub>2</sub>	d
3 - 4 h	0.8	1.0	1.5	6	1.0
8 - 10 h	1.0	1.2	1.8	60	1.2
10 - 24 h	1.4	1.6	2.0	120	1.4

**FS = F<sub>1</sub> x F<sub>2</sub>**

- a = Carico uniforme - Uniform load - gleichmäßige Belastung
- b = Carico variabile - Variable load - variable Belastung
- c = Carico a urti - Shock load - Stoßbelastung
- d = Avviamenti/ora - Start/stops per hour - Schaltungen/Stunde

- PESI &  
 LUBRIFICANTI  
 - WEIGHTS &  
 LUBRICANTS  
 - GEWICHTE &  
 SCHMIERMITTEL

RS	kg	l	RA	kg	l <sub>1/2</sub>	RS / RS	kg	l <sub>1/2</sub>
28	1.1	0.03	63 / 40	4.0	0.04/0.08	28 / 28	2.5	0.03/0.03
40	2.5	0.08	63 / 50	5.3	0.04/0.13	28 / 40	3.9	0.03/0.08
50	3.8	0.13	63 / 60	8.0	0.04/0.20	28 / 50	5.2	0.03/0.13
60	6.5	0.20	71 / 50	6.6	0.06/0.13	28 / 60	7.9	0.03/0.20
70	9.0	0.35	71 / 60	9.3	0.06/0.20	40 / 70	12.0	0.08/0.35
85	13.5	0.60	71 / 70	11.8	0.06/0.35	40 / 85	16.5	0.08/0.60
110	36.0	1.50	71 / 85	16.3	0.06/0.60	50 / 110	40.5	0.13/1.50
130	50.0	2.75	80 / 60	10.5	0.10/0.20	60 / 130	57.0	0.25/2.75
150	80.0	4.40	80 / 70	13.0	0.10/0.35	70 / 150	90.0	0.35/4.40
			80 / 85	17.5	0.10/0.60			
			80 / 110	40.0	0.10/1.50			
			130	64.0	0.20/2.75			
			150	94.0	0.20/4.40			

CARICHI ENTRATA - CARICHI USCITA  
INPUT LOADS - OUTPUT LOADS  
INGANGSKRÄFTE - AUSGANGSKRÄFTE

CARICHI RADIALI ENTRATA  $R_1$  [daN]  
INPUT RADIAL LOADS  $R_1$  [daN]  
RADIALKRÄFTE EINGANG  $R_1$  [daN]

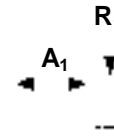

$A_1 = 0.2 \times R_1$

min <sup>-1</sup>	2800	1400	900	700	500	300
RS28	5	7	8	9	10	12
RS40	11	15	16	17	18	20
RS50	15	20	22	25	28	30
RS60	23	30	33	35	37	40
RS70	26	35	40	44	47	50
RS85	34	45	52	58	62	70
RS110	57	75	80	85	92	100
RS130	70	100	105	110	115	120
RS150	90	120	125	130	140	150

CARICHI RADIALI USCITA  $R_2$  [daN] CON CUSCINETTI STANDARD  
OUTPUT RADIAL LOADS  $R_2$  [daN] WITH STANDARD BEARINGS  
RADIALKRÄFTE AUSGANG  $R_2$  [daN] MIT STANDARDLAGERUNG

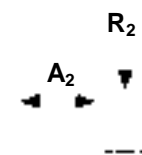

$A_2 = 0.2 \times R_2$

min <sup>-1</sup>	200	140	93	70	50	35	29	25	20	18	14	Brg No.
RS28	45	50	55	60	62	70	75	80	90	95	100	16005
RS40	100	110	120	135	150	160	170	180	190	200	230	16006
RS50	125	145	170	190	200	230	240	260	280	290	320	16008
RS60	240	250	290	330	360	390	430	320	500	420	560	6008
RS70	270	290	360	390	420	450	520	550	590	630	670	6009
RS85	330	370	440	470	540	550	630	660	710	750	830	6010
RS110	390	415	520	540	590	570	750	780	800	880	980	6012
RS130	500	565	615	650	660	780	880	950	970	1050	1150	6015
RS150	650	770	830	880	900	1100	1200	1250	1300	1400	1500	6216



CARICHI ENTRATA - CARICHI USCITA  
INPUT LOADS - OUTPUT LOADS  
INGANGSKRÄFTE - AUSGANGSKRÄFTE

CARICHI RADIALI ENTRATA  $R_1$  [daN]  
INPUT RADIAL LOADS  $R_1$  [daN]  
RADIALKRÄFTE EINGANG  $R_1$  [daN]

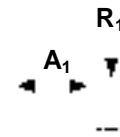

$A_1 = 0.2 \times R_1$

min <sup>-1</sup>	2800	1400	900	700	500	300
RS28	5	7	8	9	10	12
RS40	11	15	16	17	18	20
RS50	15	20	22	25	28	30
RS60	23	30	33	35	37	40
RS70	26	35	40	44	47	50
RS85	34	45	52	58	62	70
RS110	57	75	80	85	92	100
RS130	70	100	105	110	115	120
RS150	90	120	125	130	140	150

CARICHI RADIALI USCITA  $R_2$  [daN] CON CUSCINETTI RINFORZATI  
OUTPUT RADIAL LOADS  $R_2$  [daN] WITH HEAVY DUTY BEARINGS  
RADIALKRÄFTE AUSGANG  $R_2$  [daN] MIT VERSTÄRKTER LAGERUNG

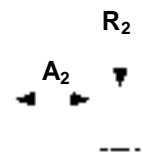

$A_2 = 0.2 \times R_2$

min <sup>-1</sup>	200	140	93	70	50	35	29	25	20	18	14	Brg No.
RS28	65	75	82	90	93	105	112	120	130	130	130	6005
RS40	150	155	165	190	210	225	240	250	260	260	260	32006
RS50	175	200	240	260	300	340	360	390	420	420	420	32008
RS60	300	320	370	420	480	510	570	610	660	660	660	32008
RS70	330	370	450	516	560	610	690	730	790	790	790	32009
RS85	420	460	550	630	720	730	840	870	940	940	940	32010
RS110	500	540	670	750	800	930	1050	1110	1110	1110	1110	32012
RS130	700	790	860	970	990	1170	1290	1420	1450	1450	1450	32015
RS150	900	1080	1160	1320	1350	1650	1800	1870	1950	1950	1950	30216

FRS	min <sup>-1</sup> IEC	i = 7	10	15	20	28	40	49	56	70	80	100
		200	140	93	70	50	35	29	25	20	18	14
28	56	★	★	★	★	★	★	★	★	★	★	★
	63	★	★	★	★	★	★	★	---	---	---	---
40	56	①	①	①	①	①	①	①	①	①	①	①
	63	★	★	★	★	★	★	★	★	★	★	★
	71	★	★	★	★	★	★	★	---	---	---	---
50	63	①	①	①	①	①	①	①	①	★	★	★
	71	★	★	★	★	★	★	★	★	★	★	★
	80	★	★	★	★	★	★	★	---	---	---	---
60	71	①	①	①	①	★	★	★	★	★	★	★
	80	★	★	★	★	★	★	★	★	★	★	★
	90	★	★	★	★	★	★	---	---	---	---	---
70	71	①	①	①	①	★	★	★	★	★	★	★
	80	★	★	★	★	★	★	★	★	★	★	★
	90	★	★	★	★	★	★	★	---	---	---	---
	100	★	★	★	---	---	---	---	---	---	---	---
85	80	①	①	①	①	①	★	★	★	★	★	★
	90	★	★	★	★	★	★	★	★	★	★	★
	100/112	★	★	★	★	★	★	---	---	---	---	---
110	90	②	②	②	②	②	☆	☆	☆	☆	☆	☆
	100/112	★	★	★	★	★	★	★	★	★	★	★
	132	★	★	★	★	---	---	---	---	---	---	---
130	90	---	---	---	---	---	---	☆	☆	☆	☆	☆
	100/112	☆	☆	☆	☆	☆	☆	☆	☆	☆	☆	☆
	132	☆	☆	☆	☆	☆	☆	---	---	---	---	---
150	90	---	---	---	---	---	---	☆	☆	☆	☆	☆
	100/112	☆	☆	☆	☆	☆	☆	☆	☆	☆	☆	☆
	132	☆	☆	☆	☆	☆	☆	☆	☆	☆	---	---
	160	☆	☆	☆	☆	☆	☆	☆	---	---	---	---

★ - B5 & B14

☆ - B5

① - Foro con boccola (IEC B5 e B14)

① - Bore with bush (IEC B5 and B14)

① - Bohrung mit Buchse (IEC B5 und B14)

② - Foro con boccola (IEC solo B5)

② - Bore with bush (IEC only B5)

② - Bohrung mit Buchse (IEC nur B5)

## FRA

GRANDEZZE MOTORI  
MOTOR FRAMES  
BAUGRÖßEN MOTOR

FRA	IEC	$i_2 = 7$	10	15	20	28	40	49	56	70	80	100
	*	**	**	**	**	**	**	**	**	**	**	**
<b>63/40</b>	56	①	①	①	①	①	①	①	①	①	①	①
<b>63/50</b>	B5&B14	①	①	①	①	①	①	①	①	①	①	①
<b>63/60</b>		---	---	---	---	①	①	①	①	①	①	①
<b>63/40</b>	63	①	①	①	①	①	①	①	①	①	①	①
<b>63/50</b>	B5&B14	①	①	①	①	①	①	①	①	①	①	①
<b>63/60</b>		---	---	---	---	①	①	①	①	①	①	①
<b>71/50</b>	71	②	②	②	②	②	②	②	---	---	---	---
<b>71/60</b>	B5&B14	②	②	②	②	②	②	②	②	②	②	②
<b>71/70</b>		②	②	②	②	②	②	②	②	②	②	②
<b>71/85</b>		---	---	---	---	---	②	②	②	②	②	②
<b>80/60</b>	80	③	③	③	③	③	---	---	---	---	---	---
<b>80/70</b>	B5&B14	③	③	③	③	③	③	③	---	---	---	---
<b>80/85</b>		③	③	③	③	③	③	③	③	③	③	③
<b>80/110</b>		④	④	④	④	③	③	③	③	③	③	③
<b>80/60</b>	90	③	③	③	③	③	---	---	---	---	---	---
<b>80/70</b>	B5&B14	③	③	③	③	③	③	③	---	---	---	---
<b>80/85</b>		③	③	③	③	③	③	③	③	③	③	③
<b>80/110</b>		④	④	④	④	③	③	③	③	③	③	③
<b>130</b>	80 B5	⑤	⑤	⑤	⑤	⑤	⑤	⑤	⑤	⑤	⑤	⑤
	90 B5	⑤	⑤	⑤	⑤	⑤	⑤	⑤	⑤	⑤	⑤	⑤
	100 B5	⑤	⑤	⑤	⑤	⑤	⑤	⑤	⑤	⑤	⑤	⑤
<b>150</b>	80 B5	⑥	⑥	⑥	⑤	⑤	⑤	⑤	⑤	⑤	⑤	⑤
	90 B5	⑥	⑥	⑥	⑤	⑤	⑤	⑤	⑤	⑤	⑤	⑤
	100 B5	⑥	⑥	⑥	⑤	⑤	⑤	⑤	⑤	⑤	⑤	⑤

\* - Entrata precoppia  
 \*\* - Uscita precoppia & Entrata FRS  
 ① -  $\varnothing 105 \times 14$   
 ② -  $\varnothing 120 \times 19$   
 ③ -  $\varnothing 140 \times 24$   
 ④ -  $\varnothing 140 \times 28$   
 ⑤ -  $\varnothing 200 \times 28$   
 ⑥ -  $\varnothing 200 \times 28$  (Foro vite  $\varnothing 38$  mm & Boccola  $\varnothing 38/\varnothing 28$ )

\* - Helical stage input  
 \*\* - Helical stage output & FRS input  
 ① -  $\varnothing 105 \times 14$   
 ② -  $\varnothing 120 \times 19$   
 ③ -  $\varnothing 140 \times 24$   
 ④ -  $\varnothing 140 \times 28$   
 ⑤ -  $\varnothing 200 \times 28$   
 ⑥ -  $\varnothing 200 \times 28$  (Wormshaft bore  $\varnothing 38$  mm & Adapter bush  $\varnothing 38/\varnothing 28$ )

\* - Eingang der Vorstufe  
 \*\* - Eingang der FRS  
 ① -  $\varnothing 105 \times 14$   
 ② -  $\varnothing 120 \times 19$   
 ③ -  $\varnothing 140 \times 24$   
 ④ -  $\varnothing 140 \times 28$   
 ⑤ -  $\varnothing 200 \times 28$   
 ⑥ -  $\varnothing 200 \times 28$  (Schneckebohrung  $\varnothing 38$  mm & Buchse  $\varnothing 38/\varnothing 28$ )

**FRS - RS**  
2800 & 1400 min<sup>-1</sup>

2800 min <sup>-1</sup>	i = min <sup>-1</sup>	7		10		15		20		28		40		49		56		70		80		100	
		400	280	187	140	100	70	57	50	40	35	28	28										
RS28	kW	0.63	0.49	0.35	0.25	0.23	0.16	0.13	0.12	0.09	0.08	0.04											
	Nm	13	14	14	13	15	14	13	12	11	10	7											
	eff.	0.86	0.83	0.79	0.77	0.69	0.64	0.61	0.54	0.49	0.49	0.46											
RS40	kW	1,5	1,2	0,82	0,56	0,49	0,36	0,30	0,26	0,21	0,19	0,15											
	Nm	31	34	34	30	34	32	31	30	29	28	26											
	eff.	0,87	0,85	0,81	0,78	0,72	0,66	0,62	0,6	0,57	0,54	0,51											
RS50	kW	3,0	2,0	1,5	0,95	0,92	0,63	0,51	0,43	0,33	0,31	0,23											
	Nm	62	59	61	52	66	59	56	53	46	49	40											
	eff.	0,88	0,86	0,82	0,8	0,75	0,69	0,66	0,64	0,58	0,58	0,52											
RS60	kW	4,4	3,5	2,6	1,9	1,6	1,1	0,72	0,73	0,60	0,52	0,34											
	Nm	93	104	110	108	116	105	85	92	92	85	68											
	eff.	0,88	0,87	0,84	0,82	0,76	0,73	0,71	0,66	0,64	0,6	0,58											
RS70	kW	5,7	4,3	3,2	2,4	2,2	1,5	1,2	1,0	0,80	0,69	0,54											
	Nm	122	130	139	136	161	155	142	130	120	115	107											
	eff.	0,89	0,88	0,85	0,83	0,78	0,74	0,7	0,68	0,63	0,61	0,58											
RS85	kW	9,6	7,5	5,3	4,3	3,1	2,4	2,0	1,7	1,3	1,1	0,93											
	Nm	205	225	234	237	235	250	242	229	210	200	190											
	eff.	0,89	0,88	0,86	0,8	0,8	0,76	0,72	0,71	0,67	0,64	0,6											
RS110	kW	17,5	14,8	10,7	8,6	7,0	5,0	4,5	3,6	3,1	3,0	2,1											
	Nm	375	445	470	490	530	520	545	490	525	540	450											
	Eff.	0,9	0,88	0,86	0,84	0,79	0,76	0,73	0,71	0,7	0,67	0,62											
RS130	kW	26,3	21,6	15,8	12,2	9,4	7,7	6,0	5,3	3,9	3,3	2,4											
	Nm	565	655	705	715	715	815	740	780	670	620	560											
	eff.	0,9	0,89	0,87	0,86	0,8	0,78	0,74	0,77	0,72	0,68	0,68											
RS150	kW	37,0	29,6	22,8	17,1	13,6	10,7	8,5	6,6	5,5	4,9	3,6											
	Nm	795	900	1015	1005	1065	1170	1090	970	950	915	845											
	eff.	0,9	0,89	0,87	0,86	0,82	0,8	0,77	0,77	0,72	0,68	0,68											
1400 min <sup>-1</sup>	i = min <sup>-1</sup>	7		10		15		20		28		40		49		56		70		80		100	
		200	140	93	70	50	35	29	25	20	18	14											
RS28	kW	0,45	0,33	0,23	0,16	0,16	0,10	0,09	0,08	0,06	0,05	0,03											
	Nm	18	18	18	16	20	17	17	15	12	12	8											
	eff.	0,84	0,81	0,77	0,74	0,66	0,62	0,57	0,51	0,45	0,45	0,43											
RS40	kW	1,1	0,81	0,55	0,38	0,37	0,25	0,21	0,18	0,14	0,12	0,09											
	Nm	45	46	44	39	48	42	41	38	36	32	29											
	eff.	0,85	0,83	0,78	0,75	0,68	0,61	0,58	0,56	0,52	0,50	0,46											
RS50	kW	1,8	1,3	0,93	0,63	0,63	0,41	0,37	0,31	0,25	0,20	0,13											
	Nm	75	75	74	65	85	72	76	71	63	58	43											
	eff.	0,86	0,84	0,78	0,76	0,71	0,64	0,62	0,60	0,53	0,52	0,47											
RS60	kW	2,8	2,3	1,6	1,2	1,0	0,75	0,62	0,54	0,46	0,37	0,25											
	Nm	113	133	130	122	139	135	128	123	122	106	83											
	eff.	0,86	0,84	0,81	0,77	0,71	0,66	0,62	0,60	0,55	0,53	0,49											
RS70	kW	4,0	3,1	2,2	1,8	1,5	1,2	0,84	0,74	0,58	0,50	0,37											
	Nm	166	180	188	194	216	238	189	180	163	154	130											
	eff.	0,88	0,86	0,83	0,81	0,75	0,71	0,67	0,64	0,59	0,56	0,52											
RS85	kW	6,2	4,6	3,4	2,9	2,2	2,0	1,4	1,2	0,96	0,86	0,55											
	Nm	259	268	289	322	319	401	316	305	290	280	210											
	eff.	0,88	0,86	0,83	0,82	0,76	0,72	0,67	0,68	0,63	0,60	0,56											
RS110	kW	12,5	9,0	6,5	5,7	4,4	3,5	2,7	2,2	2,0	1,5	1,1											
	Nm	525	532	560	647	642	691	631	595	635	525	469											
	eff.	0,88	0,87	0,84	0,83	0,76	0,73	0,71	0,70	0,67	0,66	0,61											
RS130	kW	19,0	15,0	11,0	8,5	7,5	5,5	3,9	3,7	2,7	2,4	1,8											
	Nm	807	890	960	975	1100	1140	950	1005	865	810	750											
	eff.	0,89	0,87	0,85	0,84	0,77	0,76	0,72	0,71	0,67	0,63	0,61											
RS150	kW	24,9	21,0	16,0	12,5	9,5	8,0	5,9	5,1	3,8	3,3	2,6											
	Nm	1060	1260	1410	1430	1435	1680	1440	1420	1230	1170	1120											
	eff.	0,89	0,88	0,86	0,84	0,89	0,77	0,73	0,73	0,68	0,65	0,63											

## FRS - RS 900 & 700 min<sup>-1</sup>

### TABELLA SELEZIONE SELECTION TABLE AUSWAHLTABELLE

900 min <sup>-1</sup>																							
900 min <sup>-1</sup>	i = min <sup>-1</sup>	7		10		15		20		28		40		49		56		70		80		100	
		128	90	60	45	32	23	19	16	13	11	9											
RS28	kW	0,36	0,24	0,18	0,13	0,12	0,08	0,07	0,06	0,04	0,03	0,02											
	Nm	22	20	21	19	22	20	19	16	13	11	8											
	eff.	0.82	0.78	0.72	0.70	0.61	0.56	0.52	0.45	0.43	0.40	0.37											
RS40	kW	0,84	0,64	0,44	0,30	0,28	0,19	0,16	0,14	0,12	0,10	0,08											
	Nm	52	54	52	45	52	46	43	41	40	39	36											
	eff.	0.83	0.80	0.74	0.70	0.63	0.56	0.52	0.49	0.46	0.44	0.42											
RS50	kW	1,5	1,1	0,75	0,52	0,51	0,35	0,28	0,25	0,19	0,17	0,12											
	Nm	95	95	91	79	99	85	81	80	67	67	55											
	eff.	0.85	0.81	0.76	0.72	0.65	0.58	0.56	0.54	0.47	0.46	0.42											
RS60	kW	2,4	1,9	1,4	1,0	0,87	0,56	0,43	0,40	0,32	0,28	0,19											
	Nm	150	163	166	161	175	152	135	130	125	115	94											
	eff.	0.85	0.83	0.75	0.76	0.68	0.64	0.61	0.55	0.53	0.48	0.47											
RS70	kW	3,2	2,4	1,7	1,3	1,2	0,87	0,64	0,53	0,42	0,38	0,30											
	Nm	202	211	218	207	242	240	205	187	170	160	147											
	eff.	0.86	0.83	0.79	0.77	0.70	0.65	0.62	0.59	0.54	0.50	0.46											
RS85	kW	5,0	3,9	3,0	2,1	1,8	1,5	1,0	0,83	0,73	0,64	0,51											
	Nm	320	350	378	355	373	410	350	332	300	290	260											
	eff.	0.86	0.84	0.80	0.78	0.71	0.66	0.67	0.67	0.55	0.53	0.48											
RS110	kW	9,8	8,0	5,7	4,4	3,7	2,7	2,3	1,9	1,7	1,5	0,94											
	Nm	635	720	745	745	795	780	780	690	765	715	500											
	eff.	0.87	0.85	0.82	0.79	0.73	0.68	0.64	0.62	0.59	0.57	0.50											
RS130	kW	14,9	11,7	8,4	6,5	5,1	4,1	3,1	2,8	2,1	1,8	1,3											
	Nm	975	1070	1115	1115	1145	1215	1095	1145	960	890	805											
	eff.	0.88	0.86	0.83	0.81	0.75	0.70	0.67	0.68	0.63	0.58	0.57											
RS150	kW	20,8	15,9	12,2	9,3	7,3	5,6	4,5	3,3	2,9	2,5	2,0											
	Nm	1360	1470	1635	1625	1660	1740	1600	1370	1390	1290	1230											
	eff.	0.88	0.87	0.84	0.82	0.77	0.73	0.69	0.69	0.64	0.61	0.58											
700 min <sup>-1</sup>																							
700 min <sup>-1</sup>	i = min <sup>-1</sup>	7		10		15		20		28		40		49		56		70		80		100	
		100	70	47	35	25	18	15	13	10	8.7	7											
RS28	kW	0,29	0,21	0,14	0,10	0,10	0,06	0,05	0,04	0,03	0,02	0,01											
	Nm	23	23	22	21	24	21	20	17	13	11	8											
	eff.	0.81	0.77	0.71	0.69	0.60	0.55	0.51	0.44	0.40	0.39	0.36											
RS40	kW	0,74	0,54	0,39	0,26	0,24	0,17	0,14	0,12	0,10	0,09	0,07											
	Nm	58	58	58	49	55	49	46	45	43	41	38											
	eff.	0.82	0.79	0.73	0.68	0.59	0.53	0.50	0.48	0.44	0.42	0.39											
RS50	kW	1,4	0,92	0,65	0,44	0,43	0,29	0,24	0,21	0,16	0,15	0,12											
	Nm	110	100	99	86	106	91	87	83	70	72	62											
	eff.	0.83	0.80	0.75	0.71	0.64	0.57	0.54	0.52	0.45	0.44	0.39											
RS60	kW	2,0	1,6	1,1	0,87	0,73	0,49	0,35	0,34	0,26	0,24	0,17											
	Nm	164	177	178	175	187	165	140	139	128	120	100											
	eff.	0.84	0.81	0.77	0.74	0.67	0.62	0.59	0.54	0.51	0.46	0.44											
RS70	kW	2,7	2,1	1,4	1,1	1,0	0,71	0,55	0,46	0,36	0,32	0,24											
	Nm	216	233	231	225	256	245	220	197	176	167	150											
	eff.	0.85	0.82	0.78	0.75	0.68	0.63	0.60	0.56	0.51	0.48	0.45											
RS85	kW	4,6	3,5	2,5	1,9	1,5	1,2	0,93	0,78	0,59	0,56	0,44											
	Nm	370	400	408	388	400	420	379	353	310	305	275											
	eff.	0.85	0.83	0.79	0.76	0.69	0.65	0.61	0.59	0.55	0.50	0.46											
RS110	kW	8,5	6,8	4,9	3,9	3,3	2,3	2,0	1,7	1,5	1,2	0,79											
	Nm	700	780	795	815	890	820	840	770	815	720	515											
	eff.	0.86	0.84	0.80	0.77	0.71	0.66	0.62	0.60	0.57	0.55	0.48											
RS130	kW	12,8	10,3	7,4	5,6	4,4	3,6	2,7	2,4	1,8	1,6	1,1											
	Nm	1060	1200	1230	1215	1200	1320	1185	1215	1030	955	855											
	eff.	0.87	0.85	0.81	0.80	0.72	0.68	0.65	0.66	0.61	0.56	0.55											
RS150	kW	18,0	13,7	10,6	8,1	6,2	4,9	3,8	3,0	2,6	2,3	1,7											
	Nm	1475	1610	1805	1780	1790	1890	1710	1535	1500	1425	1275											
	eff.	0.87	0.86	0.83	0.81	0.75	0.71	0.68	0.67	0.61	0.58	0.56											

## FRA - RA 1400 min<sup>-1</sup>

### TABELLA SELEZIONE SELECTION TABLE AUSWAHLTABELLE

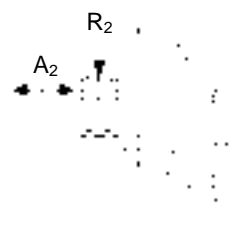
	FXA – XA 1400 min <sup>-1</sup>	i <sub>1</sub> = min <sup>-1</sup>	3.5			6.3			8			
			400	225	175							
XA63		kW Nm R <sub>2</sub> [N]	0.50	0.23	0.18							
			12	10	9							
			390	450	450							
XA71		kW Nm R <sub>2</sub> [N]	1.1	0.52	0.37							
			26	22	20							
			490	560	560							
XA80		kW Nm R <sub>2</sub> [N]	3.1	1.5	1.1							
			68	65	60							
			610	700	700							
<b>A<sub>2</sub> = 0.2 x R<sub>2</sub></b>												
<b>i<sub>1</sub> = 3.5</b>	i = i <sub>1</sub> x i <sub>2</sub> min <sup>-1</sup>	25 57	35	53	70	98	140	172	196	245	280	350
			40	27	20	14	10	8	7	6	5	4
	i <sub>2</sub>	7	10	15	20	28	40	49	56	70	80	100
RA63/40	kW Nm eff.	0.55	0.40	0.28	0.20	0.19	0.13	0.11	0.10	0.06	0.05	0.03
		72	72	70	60	70	64	58	56	42	35	25
		0.78	0.75	0.70	0.63	0.56	0.50	0.46	0.44	0.41	0.40	0.35
RA63/50 RA71/50	kW Nm eff.	1.02	0.70	0.50	0.33	0.32	0.21	0.20	0.16	0.11	0.09	0.06
		135	127	125	105	125	105	115	100	80	70	50
		0.79	0.76	0.70	0.66	0.59	0.52	0.50	0.46	0.42	0.40	0.35
RA63/60 RA71/60 RA80/60	kW Nm eff.	1.53	1.18	0.83	0.57	0.53	0.33	0.27	0.23	0.19	0.15	0.10
		205	217	215	192	217	177	170	152	145	110	85
		0.80	0.77	0.72	0.70	0.61	0.57	0.54	0.49	0.45	0.38	0.36
RA71/70 RA80/70	kW Nm eff.	1.96	1.48	1.08	0.77	0.72	0.50	0.43	0.36	0.30	0.26	0.19
		265	275	285	260	310	270	270	235	225	200	180
		0.81	0.78	0.74	0.71	0.64	0.57	0.54	0.49	0.45	0.41	0.39
RA71/85 RA80/85	kW Nm eff.	3.14	2.39	1.77	1.37	1.11	0.80	0.65	0.58	0.49	0.40	0.26
		430	450	475	470	475	445	420	410	390	340	250
		0.82	0.79	0.75	0.72	0.64	0.58	0.55	0.53	0.48	0.44	0.40
RA80/110	kW Nm eff.	6.02	4.63	3.58	2.61	2.18	1.60	1.27	1.12	0.86	0.86	0.54
		835	895	950	910	960	950	850	820	750	740	540
		0.83	0.81	0.74	0.73	0.66	0.62	0.57	0.55	0.52	0.45	0.42
RA130	kW Nm eff.	7.0	6.8	5.5	3.8	3.1	2.3	1.7	1.5	1.3	1.1	0.8
		975	1320	1495	1350	1430	1380	1300	1250	1200	1080	880
		0.83	0.81	0.77	0.75	0.67	0.63	0.64	0.62	0.60	0.50	0.48
RA150	kW Nm eff.	7.9	7.8	7.5	5.7	4.5	3.3	2.7	2.4	1.8	1.6	1.0
		1115	1535	2090	2060	2130	2050	2040	2025	1700	14595	1200
		0.84	0.82	0.79	0.76	0.69	0.66	0.64	0.62	0.60	0.52	0.50
<b>i<sub>1</sub> = 6.3</b>	i = i <sub>1</sub> x i <sub>2</sub> min <sup>-1</sup>	44 32	63	95	126	176	252	309	353	441	504	630
			22	15	11	8	5.5	4.6	4	3.2	2.8	2.2
	i <sub>2</sub>	7	10	15	20	28	40	49	56	70	80	100
RA63/40	kW Nm eff.	0.35	0.25	0.17	0.12	0.11	0.08	0.06	0.06	0.05	0.04	0.03
		79	78	74	63	69	63	57	55	53	51	46
		0.76	0.72	0.67	0.60	0.52	0.45	0.43	0.39	0.35	0.34	0.31
RA63/50 RA71/50	kW Nm eff.	0.62	0.42	0.30	0.20	0.20	0.14	0.11	0.10	0.09	0.07	0.05
		145	133	130	113	138	115	108	100	92	89	72
		0.78	0.74	0.67	0.63	0.55	0.48	0.45	0.42	0.36	0.36	0.31
RA63/60 RA71/60 RA80/60	kW Nm eff.	0.92	0.74	0.52	0.40	0.35	0.23	0.16	0.16	0.11	0.10	0.08
		218	237	235	230	238	210	160	175	141	130	122
		0.79	0.75	0.70	0.67	0.57	0.53	0.49	0.45	0.42	0.37	0.35
RA71/70 RA80/70	kW Nm eff.	1.2	0.95	0.68	0.50	0.44	0.32	0.26	0.23	0.18	0.17	0.12
		289	310	310	292	320	259	272	254	221	210	190
		0.80	0.76	0.71	0.68	0.60	0.54	0.50	0.46	0.42	0.37	0.36
RA71/85 RA80/85	kW Nm eff.	2.0	1.6	1.1	0.84	0.69	0.53	0.43	0.37	0.28	0.26	0.22
		490	526	516	495	501	500	466	449	391	380	345
		0.80	0.77	0.72	0.69	0.60	0.55	0.51	0.50	0.46	0.42	0.36
RA80/110	kW Nm eff.	4.3	3.2	2.4	1.8	1.6	1.1	1.0	0.80	0.66	0.51	0.32
		1030	1100	1150	1100	1170	1110	1100	995	950	780	550
		0.81	0.79	0.74	0.71	0.63	0.57	0.53	0.52	0.48	0.45	0.39
RA130	kW Nm eff.	2.0	1.6	1.1	0.84	0.69	0.53	0.43	0.37	0.28	0.26	0.22
		490	525	516	495	501	500	466	449	391	380	345
		0.80	0.77	0.72	0.69	0.60	0.55	0.51	0.50	0.46	0.42	0.36
RA150	kW Nm eff.	4.3	3.2	2.4	1.8	1.6	1.1	1.0	0.80	0.66	0.51	0.32
		1030	1100	1150	1100	1170	1110	1100	995	950	780	550
		0.81	0.79	0.74	0.71	0.63	0.57	0.53	0.52	0.48	0.45	0.39

## FRA - RA

1400 min<sup>-1</sup>

### TABELLA SELEZIONE SELECTION TABLE AUSWAHLTABELLE

<b>i<sub>1</sub> = 8</b>	<b>i = i<sub>1</sub> × i<sub>2</sub></b> min <sup>-1</sup>	56	80	120	160	224	320	392	448	560	640	800
		25	18	12	9	6	4	3.5	3	2.5	2.2	1.75
		i <sub>2</sub>	7	10	15	20	28	40	49	56	70	80
RA63/40	kW	0.32	0.23	0.16	0.11	0.11	0.08	0.06	0.05	0.03	0.03	0.02
	Nm	93	89	84	72	85	75	69	59	45	38	27
	eff.	0.75	0.72	0.65	0.59	0.50	0.44	0.41	0.38	0.36	0.34	0.31
RA63/50 RA71/50	kW	0.58	0.41	0.28	0.20	0.18	0.13	0.10	0.09	0.06	0.05	0.03
	Nm	170	165	154	130	150	130	120	115	86	73	53
	eff.	0.77	0.73	0.67	0.61	0.55	0.47	0.45	0.41	0.36	0.37	0.31
RA63/60 RA71/60 RA80/60	kW	0.87	0.68	0.49	0.34	0.31	0.21	0.16	0.15	0.10	0.08	0.05
	Nm	260	280	275	240	270	235	220	200	155	125	92
	eff.	0.78	0.75	0.69	0.65	0.57	0.51	0.50	0.43	0.41	0.37	0.35
RA71/70 RA80/70	kW	1.26	0.88	0.63	0.44	0.48	0.28	0.24	0.20	0.16	0.12	0.05
	Nm	380	365	360	325	440	320	320	275	245	200	145
	eff.	0.79	0.76	0.70	0.67	0.60	0.53	0.50	0.45	0.41	0.38	0.35
RA71/85 RA80/85	kW	1.76	1.42	1.07	0.85	0.65	0.48	0.40	0.33	0.26	0.20	0.13
	Nm	530	595	620	620	600	560	550	510	450	360	260
	eff.	0.79	0.77	0.71	0.67	0.60	0.54	0.52	0.50	0.45	0.41	0.37
RA80/110	kW	3.42	2.75	1.97	1.52	1.29	0.97	0.73	0.64	0.52	0.43	0.27
	Nm	1045	1170	1180	1160	1200	1180	1020	980	920	850	550
	eff.	0.80	0.78	0.73	0.70	0.61	0.56	0.52	0.50	0.46	0.45	0.38
RA130	kW	3.3	3.0	3.2	2.3	1.8	1.2	1.1	0.9	0.7	0.7	0.5
	Nm	1000	1240	1840	1765	1760	1700	1660	1600	1435	1330	1160
	eff.	0.80	0.78	0.73	0.72	0.62	0.58	0.56	0.54	0.51	0.45	0.43
RA150	kW	3.7	3.4	3.6	3.4	2.7	2.0	1.7	1.4	1.1	1.0	0.8
	Nm	1130	1425	2150	2580	2675	2860	2550	2490	2110	1970	1855
	eff.	0.81	0.79	0.75	0.72	0.63	0.61	0.56	0.57	0.49	0.46	0.45

## RS/RS

1400 min<sup>-1</sup>

	<b>i = i<sub>1</sub> × i<sub>2</sub></b> min <sup>-1</sup>	420	560	784	1120	1568	2240	2800	4000	5600	8000	10000
		3.3	2.5	1.8	1.25	0.9	0.6	0.5	0.35	0.25	0.17	0.14
		i <sub>1</sub> =	15	20	28	40	56	56	70	100	100	100
i <sub>2</sub> =	28	28	28	28	28	40	40	40	40	56	80	100
RS28/28	W	32	25	21	16	13	9	8	6	3	1.8	1.3
	Nm	35	36	36	36	35	30	30	30	16	12	11
	eff.	0.38	0.37	0.32	0.30	0.25	0.21	0.20	0.18	0.14	0.12	0.13
RS28/40	W	75	60	46	34	30	22	22	14	11	5	3
	Nm	85	85	80	80	80	73	76	70	62	41	25
	eff.	0.39	0.37	0.33	0.31	0.25	0.21	0.18	0.18	0.15	0.14	0.12
RS28/50	W	133	106	91	74	60	36	36	28	20	10	6
	Nm	150	150	160	175	160	125	131	147	125	78	49
	eff.	0.39	0.37	0.33	0.31	0.25	0.22	0.19	0.19	0.16	0.14	0.12
RS28/60	W	197	157	132	91	91	67	54	30	32	16	10
	Nm	240	240	245	230	260	245	217	164	195	128	91
	eff.	0.42	0.40	0.35	0.33	0.27	0.23	0.21	0.20	0.16	0.14	0.13
RS40/70	W	298	249	198	157	119	86	72	60	42	24	16
	Nm	380	400	400	395	380	370	345	360	321	201	154
	eff.	0.44	0.42	0.38	0.33	0.30	0.27	0.25	0.22	0.20	0.15	0.14
RS40/85	W	447	372	276	224	180	138	120	90	72	39	26
	Nm	595	625	585	625	610	615	595	565	550	373	264
	eff.	0.46	0.44	0.40	0.35	0.32	0.28	0.26	0.23	0.20	0.17	0.15
RS50/110	W	865	756	579	453	382	292	235	163	128	82	51
	Nm	1190	1300	1300	1280	1350	1340	1210	1070	980	810	560
	eff.	0.48	0.45	0.42	0.37	0.33	0.30	0.27	0.24	0.20	0.18	0.16
RS60/130	kW	1.5	1.1	0.75	0.55	0.55	0.37	0.25	0.25	0.25	0.25	0.25
	Nm	2015	1930	1670	1530	2015	1830	1410	1770	1850	1420	1225
	eff.	0.50	0.46	0.43	0.40	0.35	0.33	0.30	0.27	0.25	0.21	0.20
RS70/150	kW	1.8	1.5	1.1	0.75	0.75	0.55	0.37	0.37	0.25	0.25	0.25
	Nm	2570	2830	2570	2460	2850	3020	2325	2875	2670	2135	1995
	eff.	0.52	0.50	0.46	0.43	0.39	0.36	0.33	0.31	0.27	0.23	0.22

## MRS, MRA 0.06 - 0.55 kW

## TABELLA SELEZIONE SELECTION TABLE AUSWAHLTABELLE

0.06 kW (0.08 HP)						0.09 kW (0.12 HP)						0.25 kW (0.33 HP)					
	min <sup>-1</sup>	i =	Nm	SF	kg		min <sup>-1</sup>	i =	Nm	SF	kg		min <sup>-1</sup>	i =	Nm	SF	kg
MRS28	200	7	2.4	>3	3.6	MRS40/85	0.5	2800	447	1.3	19	MRS40	35	40	42	1.0	8.3
MRS28	140	10	3.3	>3	3.6	MRS40/85	0.4	4000	565	1.0	19	MRA71/50	32	44	59	2.5	12
MRS28	93	15	4.7	>3	3.6	MRS40/85	0.3	5600	688	0.8	19	MRS50	29	49	52	1.5	9.6
MRS28	70	20	6.1	2.6	3.6							MRS50	25	56	57	1.3	9.6
MRS28	50	28	7.6	2.6	3.6							MRA71/50	22	63	80	1.7	12
MRS28	35	40	10	1.7	3.6	MRS28	200	7	4.8	>3	4.8	MRS50	20	70	63	1.0	9.6
MRA63/40	32	44	14	>3	6.5	MRS28	140	10	6.6	2.7	4.8	MRS60	18	80	72	1.5	12
MRS28	29	49	11	1.5	3.6	MRS28	93	15	9.5	1.9	4.8	MRA71/50	95	95	109	1.2	12
MRS28	25	56	12	1.3	3.6	MRS28	70	20	12	1.3	4.8	MRS60	14	100	88	1.0	12
MRA63/40	22	63	19	>3	6.5	MRS28	50	28	15	1.3	4.8	MRA71/60	11	126	144	1.6	15
MRS28	20	70	13	0.9	3.6	MRS40	35	40	20	2.1	6.2	MRS40/70	9.3	150	146	1.5	18
MRS40	18	80	16	2.0	5.0	MRA63/40	32	44	27	2.9	7.7	MRA71/60	8.0	176	171	1.4	15
MRA63/40	15	95	26	2.8	6.5	MRS40	29	49	23	1.8	6.2	MRS40/70	7.0	200	188	1.5	18
MRS40	14	100	19	1.5	5.0	MRS40	25	56	26	1.5	6.2	MRA71/70	5.5	252	232	1.3	18
MRA63/40	11	126	31	2.0	6.5	MRA63/40	22	63	37	2.1	7.7	MRS40/70	5.0	280	224	1.5	18
MRS28/28	9.3	150	31	1.1	5.0	MRS40	20	70	30	1.2	6.2	MRA71/70	4.6	309	263	1.0	18
MRA63/40	8.0	176	37	1.8	6.5	MRS40	18	80	33	1.0	6.2	MRA71/70	4.0	353	277	0.9	18
MRS28/28	7.0	200	30	0.8	5.0	MRA63/40	15	95	52	1.4	7.7	MRS40/70	3.3	420	315	1.2	18
MRA63/40	5.5	252	46	1.4	6.5	MRS50	14	100	38	1.1	7.5	MRS40/70	2.5	560	401	1.0	18
MRS28/28	5.0	280	35	0.8	5.0	MRA63/40	11	126	62	1.0	7.7	MRS40/85	1.8	784	535	1.1	22
MRA63/40	4.6	309	54	1.0	6.5	MRS28/40	9.3	150	64	1.4	7.6	MRS50/110	1.3	1120	707	1.8	46
MRA63/40	4.0	353	56	1.0	6.5	MRA63/40	8.0	176	75	0.9	7.7	MRS50/110	0.9	1568	882	1.5	46
MRS28/40	3.3	420	67	1.3	6.4	MRS28/40	7.0	200	77	1.0	7.6	MRS50/110	0.6	2240	1146	1.2	46
MRA63/50	3.2	441	65	1.4	7.8	MRA63/50	5.5	252	99	1.2	9.0	MRS50/110	0.5	2800	1289	0.9	46
MRA63/50	2.8	504	74	1.2	7.8	MRS28/40	5.0	280	94	0.8	7.6						
MRS28/40	2.5	560	85	1.0	6.4	MRA63/50	4.6	309	114	0.9	9.0						
MRA63/50	2.2	630	80	0.9	7.8	MRS28/50	3.3	420	134	1.2	8.9	MRS40	200	7	15	3.0	8.7
MRS28/50	1.8	784	106	1.5	7.7	MRS28/50	2.5	560	170	0.9	8.9	MRS40	140	10	21	2.2	8.7
MRS28/50	1.3	1120	142	1.2	7.7	MRS28/60	1.8	784	225	1.1	12	MRS40	93	15	30	1.5	8.7
MRS28/50	0.9	1568	160	1.0	7.7	MRS28/60	1.3	1120	303	0.8	12	MRS40	70	20	38	1.0	8.7
MRS28/60	0.6	2240	211	1.2	10	MRS40/70	0.9	1568	385	1.0	16	MRS40	50	28	48	1.0	8.7
MRS28/60	0.5	2800	241	0.9	10	MRS40/85	0.6	2240	513	1.2	20	MRS50	35	40	65	1.1	10
MRS40/70	0.4	4000	360	1.0	15	MRS40/85	0.5	2800	596	1.0	20	MRA71/50	32	44	87	1.7	13
MRS40/70	0.3	5600	458	0.7	15	MRS40/85	0.4	4000	753	0.8	20	MRS50	29	49	77	1.0	10
MRS40/85	0.2	8000	557	0.7	19							MRS60	25	56	85	1.5	13
MRS40/85	0.1	10000	614	0.4	19							MRA71/50	22	63	118	1.1	13
						MRS28	200	7	7.2	2.5	5.4	MRS60	20	70	97	1.3	13
						MRS28	140	10	9.9	1.8	5.4	MRS60	18	80	107	1.0	13
						MRS28	93	15	14	1.3	5.4	MRA71/60	15	95	168	1.4	16
						MRS40	70	20	18	2.1	6.8	MRS70	14	100	130	1.0	15
						MRS40	50	28	23	2.1	6.8	MRA71/60	11	126	213	1.1	15
						MRS40	35	40	30	1.4	6.8	MRS40/70	9.3	150	217	2.1	18
						MRA63/40	32	44	41	1.9	8.3	MRA71/60	8.0	176	253	0.9	15
						MRS40	29	49	35	1.2	6.8	MRS40/70	7.0	200	278	1.3	18
						MRS40	25	56	39	1.0	6.8	MRA71/70	5.5	252	343	0.9	18
						MRA63/40	22	63	56	1.4	8.3	MRS40/70	5.0	280	332	1.1	18
						MRS50	20	70	46	1.4	8.1	MRS40/85	3.3	420	488	1.2	23
						MRA63/40	18	80	51	1.1	8.1	MRS40/85	2.5	560	622	1.0	23
						MRS50	15	95	78	0.9	8.3	MRS50/110	1.3	1120	1046	1.2	47
						MRA63/50	11	126	97	1.2	9.6	MRS50/110	0.9	1568	1306	1.1	47
						MRS28/50	9.3	150	93	1.6	9.5						
						MRA63/50	8.0	176	119	1.2	9.6						
						MRS28/50	7.0	200	120	1.1	9.5	MRS50	200	7	23	>3	12
						MRS28/50	5.0	280	141	1.1	9.5	MRS50	140	10	32	2.4	12
						MRS28/60	3.3	420	217	1.1	12	MRS50	93	15	44	1.7	12
						MRS40/70	2.5	560	289	1.4	16	MRS50	70	20	57	1.1	12
						MRS40/70	1.8	784	366	1.1	16	MRS50	50	28	75	1.1	12
						MRS40/85	1.3	1120	481	1.3	21	MRS60	35	40	99	1.4	15
						MRS40/85	0.9	1568	616	1.0	21	MRA80/60	32	44	130	1.7	19
						MRS40/85	0.6	2240	770	0.8	21	MRS60	29	49	114	1.1	15
												MRS60	25	56	126	1.0	15
												MRA80/60	22	63	177	1.2	19
						MRS40	200	7	10	>3	8.3	MRS70	20	70	155	1.1	18
						MRS40	140	10	14	>3	8.3	MRS70	18	80	168	1.0	18
						MRS40	93	15	20	2.2	8.3	MRA80/60	15	95	249	1.0	19
						MRS40	70	20	26	1.5	8.3	MRS85	14	100	210	1.0	22
						MRS40	50	28	32	1.5	8.3	MRA80/70	11	126	321	1.1	22



**MRS, MRA  
0.55 - 15 kW**
**TABELLA SELEZIONE  
SELECTION TABLE  
AUSWAHLTABELLE**

	0.55 kW (0.75 HP)						1.5 kW (2 HP)						4 kW (5.5 HP)				
	min <sup>-1</sup>	i =	Nm	SF	kg		min <sup>-1</sup>	i =	Nm	SF	kg		min <sup>-1</sup>	i =	Nm	SF	kg
MRA80/85	8.0	176	396	1.3	26	MRS110	29	49	356	1.8	50	MRA150	18	80	1724	0.9	123
MRA80/85	5.5	252	520	1.0	26	MRS110	25	56	401	1.5	50	MRA150	14	98	1845	1.2	123
MRA80/110	4.6	309	614	1.8	49	MRA80/85	22	63	496	1.1	31	MRA150	12	120	2456	0.9	123
MRA80/110	4.0	353	689	1.4	49	MRS110	20	70	480	1.3	50	5.5 kW (7.5 HP)					
MRS50/110	3.3	420	756	1.1	49	MRS110	18	80	540	1.0	50	MRS110	200	7	231	2.3	79
MRA80/110	3.2	441	794	1.2	49	MRA80/110	15	95	719	1.6	54	MRS110	140	10	326	1.6	79
MRA80/110	2.8	504	851	0.9	49	MRS130	14	100	624	1.2	64	MRS110	93	15	473	1.2	79
MRS50/110	2.5	570	962	1.3	49	MRA80/110	11	126	915	1.2	54	MRS110	70	20	623	1.0	79
MRS50/110	1.8	784	1235	1.5	49	MRA80/110	8.0	176	1135	1.0	54	MRS110	70	20	623	1.0	79
0.75 kW (1 HP)						MRA130	7.0	200	1269	1.0	78	MRS130	50	28	809	1.4	93
MRS50	200	7	31	2.4	14	MRA130	6.3	224	1421	1.2	78	MRS130	35	40	1141	1.0	93
MRS50	140	10	43	1.7	14	MRA150	5.0	280	1490	1.1	108	MRS150	29	49	1342	1.1	123
MRS50	93	15	60	1.2	14	MRA150	3.5	400	2292	1.1	108	MRA130	27	53	1531	1.0	107
MRS60	70	20	79	1.5	17	MRA150	3.0	448	2613	1.0	108	MRS150	25	56	1534	0.9	123
MRS60	50	28	102	1.4	17	2.2 kW (3 HP)						7.5 kW (10 HP)					
MRS60	35	40	135	1.0	17	MRS70	200	7	92	1.8	28	MRS110	200	7	315	1.7	88
MRA80/60	32	44	178	1.2	20	MRS70	140	10	129	1.4	28	MRS110	140	10	445	1.2	88
MRS70	29	49	168	1.1	19	MRS70	93	15	187	1.0	28	MRS110	93	15	645	0.9	88
MRS70	25	56	183	1.0	19	MRS85	70	20	246	1.3	33	MRS130	93	15	652	1.5	102
MRA80/60	22	63	242	1.0	20	MRS85	50	28	319	1.0	33	MRS130	70	20	860	1.1	102
MRS85	20	70	226	1.3	23	MRS85	35	40	438	1.6	55	MRS130	50	28	1103	1.0	102
MRS85	18	80	246	1.1	23	MRS110	29	49	522	1.2	55	MRS150	35	40	1576	1.1	132
MRA80/70	11	126	341	0.9	23	MRS110	25	56	588	1.0	55	MRA130	26	53	1041	1.4	116
MRA80/85	8.0	176	540	0.9	27	MRS110	20	70	704	0.9	55	MRA150	25	56	1036	1.1	146
MRA80/110	5.5	252	735	1.5	50	MRS130	18	80	756	1.1	69	11 kW (15 HP)					
MRA80/110	4.6	309	838	1.3	50	MRS150	14	100	945	1.2	99	MRS150	200	7	467	2.3	148
MRA80/110	4.0	353	939	1.1	50	MRA130	14	98	985	1.5	83	MRS150	140	10	660	1.9	148
MRS50/110	3.3	420	1031	1.2	50	MRA130	12	125	1369	1.3	83	MRS150	93	15	968	1.5	148
MRA80/110	3.2	441	1083	0.9	50	MRA130	10	140	1324	1.0	83	MRS150	93	15	968	1.5	148
MRS50/110	2.5	570	1289	1.0	50	MRA130	8.9	160	1729	1.0	83	MRS150	70	20	1261	1.1	148
1.1 kW (1.5 HP)						MRA150	7.0	200	1861	1.1	113	MRS150	50	28	1660	0.9	148
MRS60	200	7	45	2.5	19	MRA150	6.3	230	2175	1.2	113	15kW (20 HP)					
MRS60	140	10	63	2.1	19	3 kW (4 HP)						MRS150	200	7	637	1.7	158
MRS60	93	15	91	1.4	19	MRS70	200	7	126	1.3	30	MRS150	140	10	900	1.4	158
MRS60	70	20	116	1.1	19	MRS70	140	10	176	1.0	30	MRS150	93	15	1320	1.1	158
MRS70	50	28	158	1.4	21	MRS85	93	15	255	1.1	35						
MRS70	35	40	213	1.1	21	MRS85	70	20	336	1.0	35						
MRA80/70	32	44	264	1.1	25	MRS110	50	28	435	1.5	57						
MRS85	29	49	246	1.3	26	MRS110	35	40	598	1.2	57						
MRS85	25	56	286	1.1	26	MRS110	29	49	712	0.9	57						
MRA80/85	22	63	364	1.4	30	MRS130	29	49	722	1.3	71						
MRS110	20	70	352	1.8	48	MRS130	25	56	814	1.2	71						
MRS110	18	80	396	1.3	48	MRA80/110	25	56	917	1.1	61						
MRA80/85	15	95	513	1.0	30	MRS150	20	70	974	1.3	101						
MRS110	14	100	458	1.0	48	MRA130	20	70	1074	1.3	85						
MRA80/110	11	126	671	1.6	52	MRS150	18	80	1064	1.1	101						
MRA80/110	8.0	176	832	1.4	52	MRA130	18	80	1277	1.0	85						
MRA80/110	5.5	252	1078	1.0	52	MRS150	14	100	1289	0.9	101						
MRA80/110	4.6	309	1229	0.9	52	MRA130	14	98	1344	1.1	85						
MRA130	3.5	400	1681	1.0	76	MRA130	12	120	1793	1.0	85						
MRS60/130	3.3	420	1576	1.3	69	MRA150	10	140	1891	1.1	115						
MRA150	3.0	448	1916	1.3	106	MRA150	8.9	160	2357	1.1	115						
MRA150	2.5	560	2059	1.0	106	4 kW (5.5 HP)											
MRA150	2.2	640	2209	0.9	106	MRS85	200	7	168	1.5	43						
MRS70/150	1.8	784	2706	0.9	102	MRS85	140	10	235	1.1	43						
1.5 kW (2 HP)						MRS110	93	15	344	1.6	65						
MRS60	200	7	62	1.8	20	MRS110	70	20	453	1.4	65						
MRS60	140	10	86	1.5	20	MRS110	50	28	581	1.1	65						
MRS60	93	15	124	1.0	20	MRS130	35	40	829	1.4	79						
MRS70	70	20	166	1.2	23	MRS130	29	49	963	1.0	79						
MRS70	50	28	215	1.0	23	MRS130	25	56	1085	0.9	79						
MRS85	35	40	295	1.4	27	MRS150	25	56	1115	1.3	109						
MRA80/85	32	44	360	1.4	31	MRS150	20	70	1299	0.9	109						
MRS85	29	49	336	0.9	27	MRA130	20	70	1433	0.9	93						
-Motori : 4 poli, 1400 min <sup>-1</sup> Peso motoriduttore [kg]																	
-Motors : 4 poles, 1400 rpm Weight of motorized unit [kg]																	
-Motoren : 4 polig, 1400 min <sup>-1</sup> Gewicht Getriebemotor [kg]																	

**MRS  
FRS - RS**

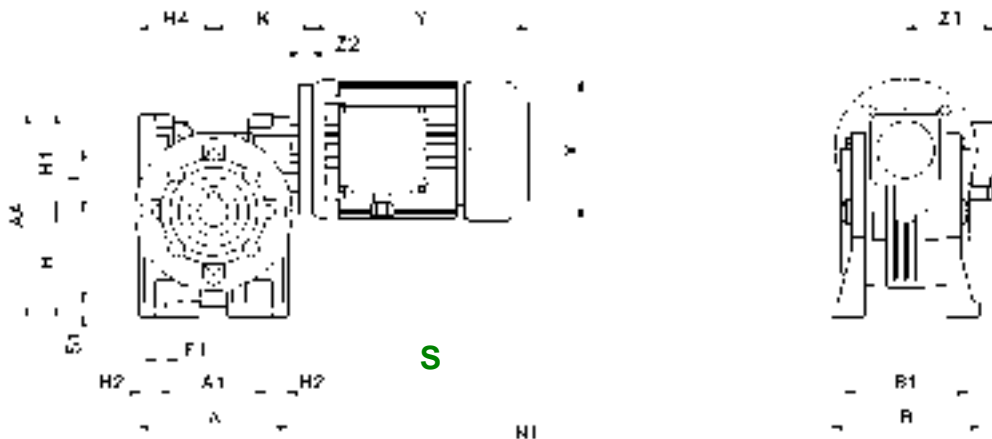

**S**

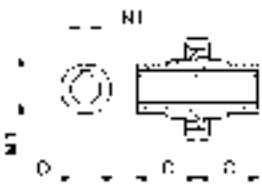

**R1**

**R**

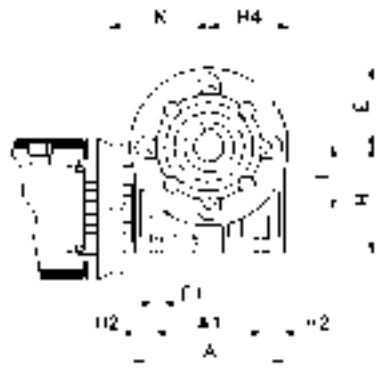

**I**

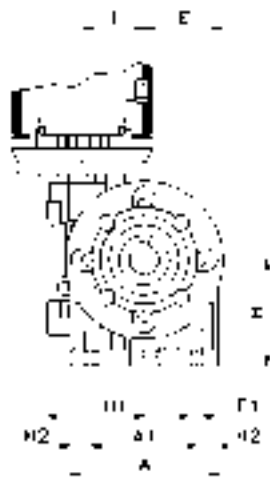

**D**

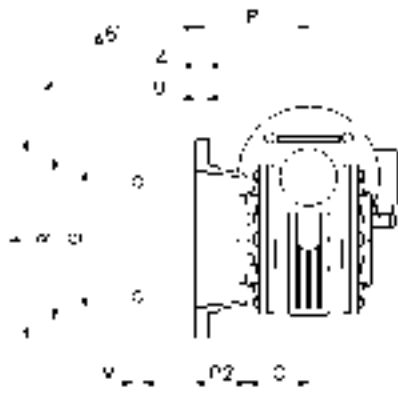

**FL**

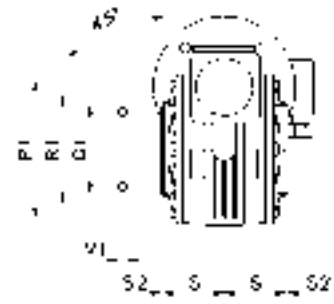

**PC**

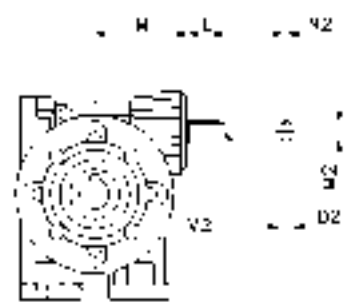

**RS**

## DIMENSIONI DI INGOMBRO OVERALL DIMENSIONS ABMESSUNGEN

RS	28	40	50	60	70	85	110	130	150
A	70	100	120	138	158	193	250	286	336
A <sub>1</sub>	52	70	85	95	120	140	200	235	260
AA	99	138	163	192	221	252	342	400	454
B	78	102	119	136	140	168	200	230	250
B <sub>1</sub>	66	84	99	111	116	140	162	190	210
C	30	41	49	60	60	61	77,5	90	105
D <sup>(H7)</sup>	14	19	24	25	28	32	42	48	55
D* <sup>(H7)</sup>	---	18	25	---	30	35	---	---	---
D <sub>2</sub> <sup>(h6)</sup>	9	11	14	19	19	24	28	38	42
E	34	50	61	70	80	98	125	143	168
F	70	140	160	180	200	200	250	300	350
F <sub>1</sub>	5,5	7	9	11	11	13	14	15	19
G <sup>(H8)</sup>	40	95	110	115	130	130	180	230	250
G <sub>1</sub> <sup>(f8)</sup>	42	60	70	70	80	110	130	180	180
H	52	71	85	100	115	135	172	200	230
H <sub>1</sub>	47	67	78	92	106	117	170	200	224
H <sub>2</sub>	9	15	17,5	21,5	19	26,5	25	25,5	38
H <sub>4</sub>	40	50	60	72	86	103	142	159	189
I	28	40	50	60	70	85	110	130	150
K	57,5	70,5	83-88*	93-94*	117-118*	134-137*	151-153*	165-166*	191-211*
L	20	23	30	40	40	40	60	80	100
M	50	65	75	87	110	123,5	146	166	195
M <sub>1</sub>	16,3	21,8	27,3	28,3	31,3	35,3	45,3	51,8	59,3
M <sub>2</sub>	10,2	12,5	16	22,5	22,5	27	31	41	45
N <sub>1</sub>	5	6	8	8	8	10	12	14	16
N <sub>2</sub>	3	4	5	6	6	8	8	10	12
P	49	82	91,5	116	111	100	150	150	160
P <sub>1</sub>	67	94	100	102	118	150	200	234	250
P <sub>2</sub>	19	41	42,5	56	51	39	72,5	60	55
R	56	115	130	150	165	165	215	265	300
R <sub>1</sub>	56	83	85	85	100	130	165	215	215
S	32	38	49	57,5	57	56,5	74,5	87	102
S <sub>1</sub>	6	9	12	12	14	15	17	19	20
S <sub>2</sub>	-3	2	2,5	2,5	3	3	2,5	5	5
U	4	6	10	10	12	6	5	5	6
V	6,5 (4)	9 (4)	9 (4)	11 (4)	13 (4)	13 (4)	15 (8)	15 (8)	19 (8)
V <sub>1</sub>	M6x6 (4)	M6x9 (4)	M8x12 (4)	M8x15 (8)	M8x18 (8)	M10x20 (8)	M12x21 (4)	M12x24 (4)	M14x30 (8)
V <sub>2</sub>	M4x10	M4x10	M6x15	M8x20	M8x20	M8x20	M8x20	M10x22	M12x25
Z	6	10	10	11	14	14	16	18	20

D\* - Foro a richiesta

- Bore on demand

- auf Anfrage

V<sub>1</sub> - 90° per RS28

- 90° for RS28

- 90° für RS28

(\*) - IEC71-B14 (FRS50) - IEC71-B14 (FRS60) - IEC 80-B14 (FRS70) - IEC 90-B14 (FRS85)

(\*) - IEC100/112-B14 (FRS110) - IEC 100/112-B5 (FRS130) - IEC 160-B5 (FRS150)

Dimensioni motore: vedi pag. 28

- Motor dimensions: see page 28

- Abmessungen Motor: siehe Seite 28

Dimensioni non impegnative

- Not binding dimensions

- unverbindliche Abmessungen

**MRA  
FRA - RA**

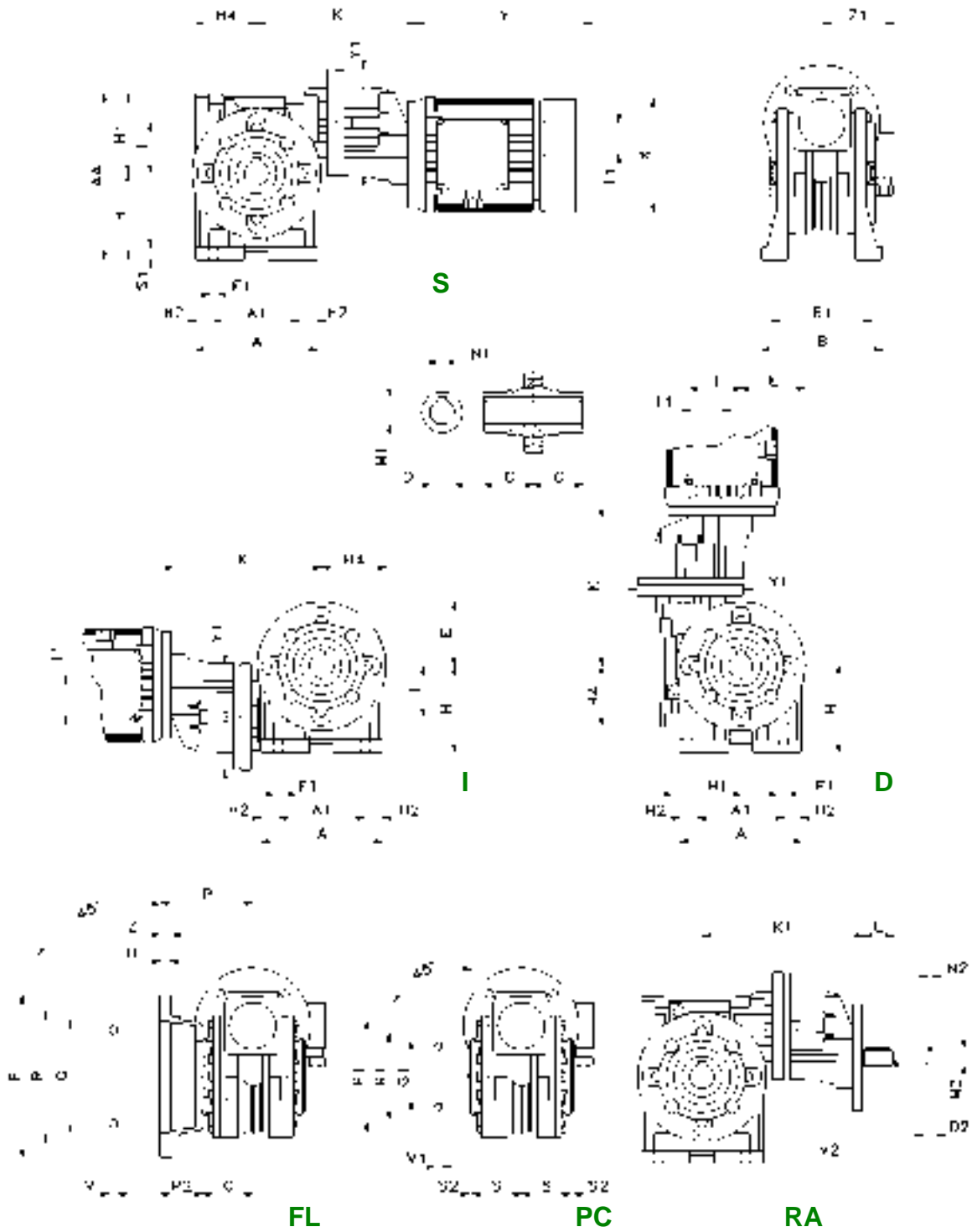

## DIMENSIONI DI INGOMBRO OVERALL DIMENSIONS ABMESSUNGEN

RA	63/40	63/50	63/60	71/50	71/60	71/70	71/85	80/60	80/70	80/85	80/110	130	150
A	100	120	138	120	138	158	193	138	158	193	250	286	336
A <sub>1</sub>	70	85	95	85	95	120	140	95	120	140	200	235	260
AA	138	163	192	163	192	221	252	192	221	252	342	400	454
B	102	119	136	119	136	140	168	136	140	168	200	230	250
B <sub>1</sub>	84	99	111	99	111	116	140	111	116	140	162	190	210
C	41	49	60	49	60	60	61	60	60	61	77,5	90	105
D <sup>(H7)</sup>	19	24	25	24	25	28	32	25	28	32	42	48	55
D* <sup>(H7)</sup>	18	25	---	25	---	30	35	---	30	35	---	---	---
D <sub>2</sub> <sup>(h6)</sup>	11	11	11	14	14	14	14	19	19	19	19	19	19
E	50	61	70	61	70	80	98	70	80	98	125	143	168
F	140	160	180	160	180	200	200	180	200	200	250	300	350
F <sub>1</sub>	7	9	11	9	11	11	13	11	11	13	14	15	19
G <sup>(H8)</sup>	95	110	115	110	115	130	130	115	130	130	180	230	250
G <sub>1</sub> <sup>(f8)</sup>	60	70	70	70	70	80	110	70	80	110	130	180	180
H	71	85	100	85	100	115	135	100	115	135	172	200	230
H <sub>1</sub>	67	78	92	78	92	106	117	92	106	117	170	200	224
H <sub>2</sub>	15	17,5	21,5	17,5	21,5	19	26,5	21,5	19	26,5	25	25,5	38
H <sub>4</sub>	50	60	72	60	72	86	103	72	86	103	142	159	189
I	40	50	60	50	60	70	85	60	70	85	110	130	150
I <sub>1</sub>	32	32	32	40	40	40	40	50	50	50	50	75	75
K	153,5	171	177	173 178*	183 188*	209 214*	224 229*	207	232,5	250,5	264,5	290 300*	316 326*
L	23	23	23	30	30	30	30	40	40	40	40	40	40
M <sub>1</sub>	21,8	27,3	28,3	27,3	28,3	31,3	35,3	28,3	31,3	35,3	45,3	51,8	59,3
M <sub>2</sub>	12,5	12,5	12,5	16	16	16	16	22,5	22,5	22,5	22,5	22,5	22,5
N <sub>1</sub>	6	8	8	8	8	8	10	8	8	10	12	14	16
N <sub>2</sub>	4	4	4	5	5	5	5	6	6	6	6	6	6
P	82	91,5	116	91,5	116	111	100	116	111	100	150	150	160
P <sub>1</sub>	94	100	102	100	102	118	150	102	118	150	200	234	250
P <sub>2</sub>	41	42,5	56	42,5	56	51	39	56	51	39	72,5	60	55
R	115	130	150	130	150	165	165	150	165	165	215	265	300
R <sub>1</sub>	83	85	85	85	85	100	130	85	100	130	165	215	215
S	38	49	57,5	49	57,5	57	56,5	57,5	57	56,5	74,5	87	102
S <sub>1</sub>	9	12	12	12	12	14	15	12	14	15	17	19	20
S <sub>2</sub>	2	2,5	2,5	2,5	2,5	3	3	2,5	3	3	2,5	5	5
U	6	10	10	10	10	12	6	10	12	6	5	5	6
V	9 (4)	9 (4)	11 (4)	9 (4)	11 (4)	13 (4)	13 (4)	11 (4)	13 (4)	13 (4)	15 (8)	15 (8)	19 (8)
V <sub>1</sub>	M6x9 (4)	M8x12 (4)	M8x15 (8)	M8x12 (4)	M8x15 (8)	M8x18 (8)	M10x20 (8)	M8x15 (8)	M8x18 (8)	M10x20 (8)	M12x21 (4)	M12x24 (4)	M14x30 (4)
V <sub>2</sub>	M4x10	M4x10	M4x10	M6x15	M6x15	M6x15	M6x15	M8x20	M8x20	M8x20	M8x20	M8x20	M8x20
Y <sub>1</sub>	105	105	105	120	120	120	120	140	140	140	140	200	200
Z	10	10	11	10	11	14	14	11	14	14	16	18	20

D\* - Foro a richiesta

- Bore on demand

- auf Anfrage

V<sub>1</sub> - 90° per RS28

- 90° for RS28

- 90° für RS28

(\*) - IEC71-B14 (FRA 71/....) - IEC100-B5 ( FRA130 ) - IEC100-B5 ( FRA150 )

Dimensioni motore: vedi pag. 28

- Motor dimensions: see page 28

- Abmessungen Motor: siehe Seite 28

Dimensioni non impegnative

- Not binding dimensions

- unverbindliche Abmessungen

**MRS/RS  
FRS/RS – RS/RS**

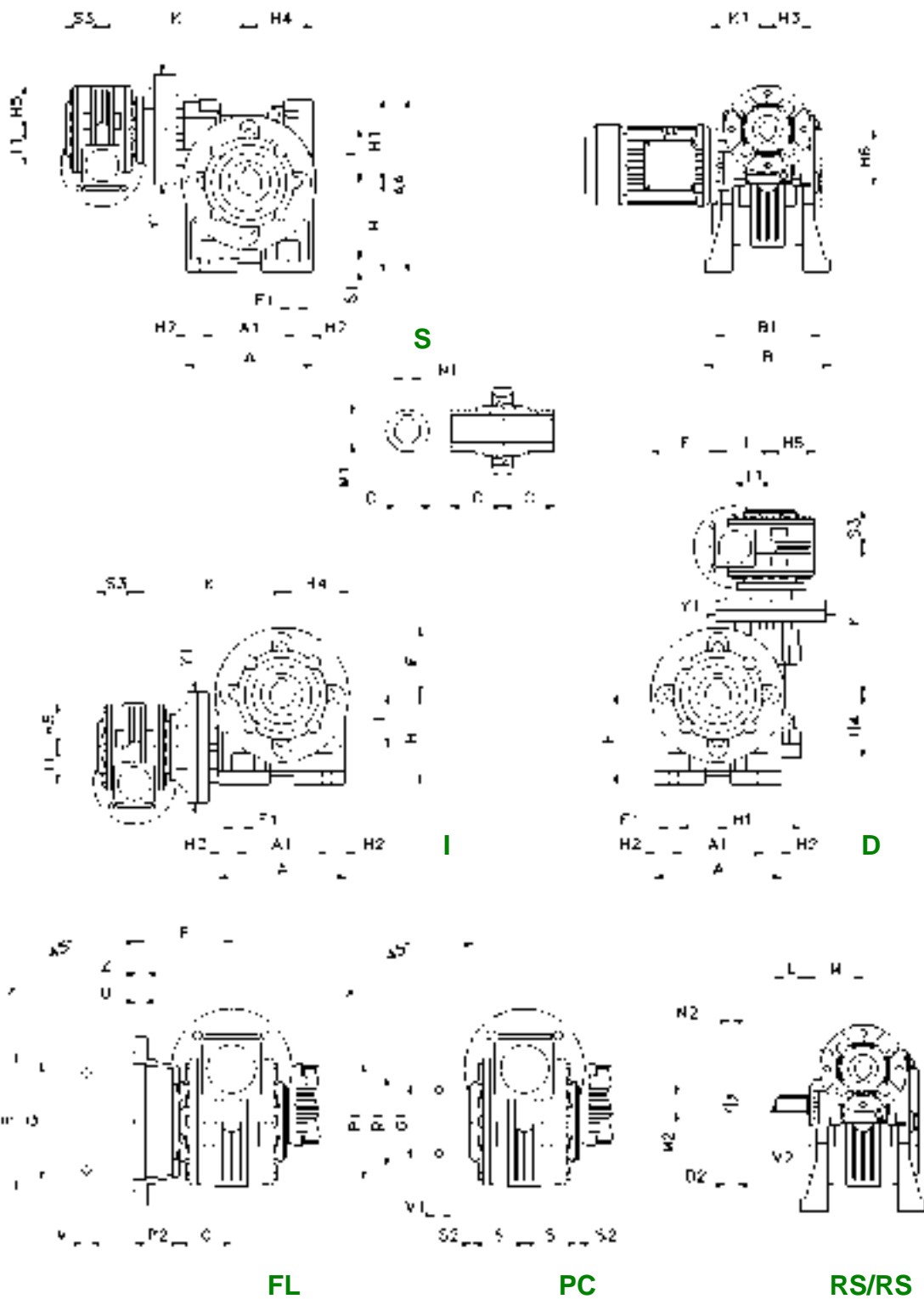

DIMENSIONI DI INGOMBRO  
OVERALL DIMENSIONS  
ABMESSUNGEN

RS/RS	28/28	28/40	28/50	28/60	40/70	40/85	50/110	60/130	70/150
A	70	100	120	138	158	193	250	286	336
A <sub>1</sub>	52	70	85	95	120	140	200	235	260
AA	99	138	163	192	221	252	342	400	454
B	78	102	119	136	140	168	200	230	250
B <sub>1</sub>	66	84	99	111	116	140	162	190	210
C	30	41	49	60	60	61	77,5	90	105
D <sup>(H7)</sup>	14	19	24	25	28	32	42	48	55
D* <sup>(H7)</sup>	---	18	25	---	30	35	---	---	---
D <sub>2</sub> <sup>(h6)</sup>	9	9	9	9	11	11	14	38	42
E	34	50	61	70	80	98	125	143	168
F	70	140	160	180	200	200	250	300	350
F <sub>1</sub>	5,5	7	9	11	11	13	14	15	19
G <sup>(H8)</sup>	40	95	110	115	130	130	180	230	250
G <sub>1</sub> <sup>(f8)</sup>	42	60	70	70	80	110	130	180	180
H	52	71	85	100	115	135	172	200	230
H <sub>1</sub>	47	67	78	92	106	117	170	200	224
H <sub>2</sub>	9	15	17,5	21,5	19	26,5	25	25,5	38
H <sub>3</sub>	40	40	40	40	50	50	60	72	86
H <sub>4</sub>	40	50	60	72	86	103	142	159	189
H <sub>5</sub>	34	34	34	34	50	50	61	70	80
H <sub>6</sub>	47	47	47	47	67	67	78	92	106
I	28	40	50	60	70	85	110	130	150
I <sub>2</sub>	28	28	28	28	40	40	50	60	70
K	99,5	116	138,5	146	182	199	246	246	300
K <sub>1</sub>	57,5	57,5	57,5	57,5	70,5	70,5	83 - 88*	93 - 94*	117-118*
L	20	20	20	20	23	23	30	40	40
M	50	50	50	50	65	65	75	87	110
M <sub>1</sub>	16,3	21,8	27,3	28,3	31,3	35,3	45,3	51,8	59,3
M <sub>2</sub>	10,2	10,2	10,2	10,2	12,5	12,5	16	22,5	22,5
N <sub>1</sub>	5	6	8	8	8	10	12	14	16
N <sub>2</sub>	3	3	3	3	4	4	5	6	6
P	49	82	91,5	116	111	100	150	150	160
P <sub>1</sub>	67	94	100	102	118	150	200	234	250
P <sub>2</sub>	19	41	42,5	56	51	39	72,5	60	55
R	56	115	130	150	165	165	215	265	300
R <sub>1</sub>	56	83	85	85	100	130	165	215	215
S	32	38	49	57,5	57	56,5	74,5	87	102
S <sub>1</sub>	6	9	12	12	14	15	17	19	20
S <sub>2</sub>	-3	2	2,5	2,5	3	3	2,5	5	5
S <sub>3</sub>	30	30	30	30	41	41	49	60	60
U	4	6	10	10	12	6	5	5	6
V	6,5 (4)	9 (4)	9 (4)	11 (4)	13 (4)	13 (4)	15 (8)	15 (8)	19 (8)
V <sub>1</sub>	M6x6 (4)	M6x9 (4)	M8x12 (4)	M8x15 (8)	M8x18 (8)	M10x20 (8)	M12x21 (4)	M12x24 (4)	M14x30 (4)
V <sub>2</sub>	M4x10	M4x10	M4x10	M4x10	M4x10	M4x10	M6x15	M8x20	M8x20
Y <sub>1</sub>	80	80	80	90	115	115	110	180	200
Z	6	10	10	11	14	14	16	18	20

D\* - Foro a richiesta

- Bore on demand

- auf Anfrage

V<sub>1</sub> - 90° per RS28

- 90° for RS28

- 90° für RS28

(\*) - IEC71-B14 (FRS50) - IEC71-B14 (FRS60) - IEC 80-B14 (FRS70)

Dimensioni motore: vedi pag. 28

- Motor dimensions: see page 28

- Abmessungen Motor: siehe Seite 28

Dimensioni non impegnative

- Not binding dimensions

- unverbindliche Abmessungen

SA - IA - DA  
 FA - FB - FR  
 PA - PB

VARIANTI COSTRUTTIVE  
 ALTERNATIVE MOUNTINGS  
 AUSFÜHRUNGSVARIANTEN

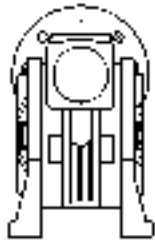

B1

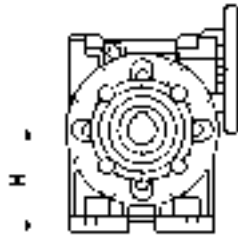

F1 A1

**SA**

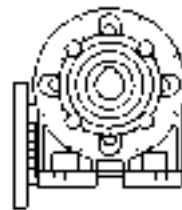

F1 A1

**IA**

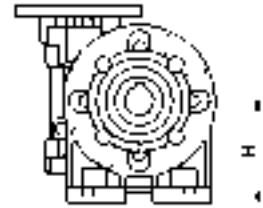

F1 A1

**DA**

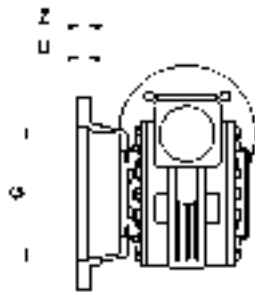

Z U G P

**FA - FB - FR**

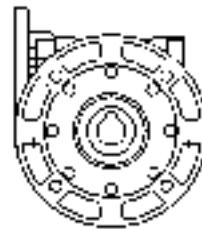

V R F

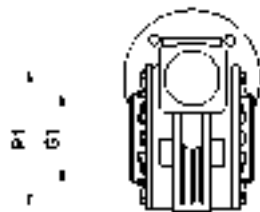

P1 G1

S2 S

**PA - PB**

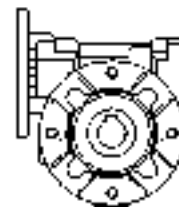

V1 R1



DIMENSIONI DI INGOMBRO  
OVERALL DIMENSIONS  
ABMESSUNGEN

RS	28	40	50	60	70	85	110	130	150
<b>SA – IA - DA</b>									
A <sub>1</sub>	---	52	63	---	---	140	---	---	---
B <sub>1</sub>	---	81	98.5	---	---	146	---	---	---
F <sub>1</sub>	---	8.5	9	---	---	11	---	---	---
H	---	72	82	---	---	142	---	---	---
<b>FA</b>									
F	80	105	125	165	165	---	---	---	---
G <sub>(H8)</sub>	50	60	70	110	115	---	---	---	---
P	50.5	69	93	90	116	---	---	---	---
R	68	87	90	130	150	---	---	---	---
U	3.5	5	5	10	4.5	---	---	---	---
V	6.5 (4)	9 (4)	11 (4)	10.5 (4)	11 (4)	---	---	---	---
Z	7	8	10	15	10	---	---	---	---
<b>FB</b>									
F	---	120	---	180	---	210	270	---	---
G <sub>(H8)</sub>	---	80	---	115	---	152	170	---	---
P	---	62	---	86	---	119.5	131.5	---	---
R	---	100	---	150	---	176	230	---	---
U	---	4	---	3.5	---	5	5	---	---
V	---	9 (4)	---	11 (4)	---	11 (4)	13 (4)	---	---
Z	---	9	---	12	---	14	18	---	---
<b>FR</b>									
F	---	---	---	---	160	---	---	---	---
G <sub>(H8)</sub>	---	---	---	---	110	---	---	---	---
P	---	---	---	---	84.5	---	---	---	---
R	---	---	---	---	130	---	---	---	---
U	---	---	---	---	4.5	---	---	---	---
V	---	---	---	---	11 (4)	---	---	---	---
Z	---	---	---	---	14	---	---	---	---
<b>PA</b>									
G <sub>1 (H8)</sub>	---	50	68	75	90	---	---	---	---
P <sub>1</sub>	---	95	110	104	125	---	---	---	---
R <sub>1</sub>	---	65	94	90	110	---	---	---	---
S	---	38	49	47.5	55	---	---	---	---
S <sub>2</sub>	---	2	2.5	5.5	3	---	---	---	---
V <sub>1</sub>	---	M6x8 (4)	M6x12.5(4)	M8x14 (4)	M8x14 (4)	---	---	---	---
<b>PB</b>									
G <sub>1 (H8)</sub>	---	---	60	---	70	---	---	---	---
P <sub>1</sub>	---	---	110	---	116	---	---	---	---
R <sub>1</sub>	---	---	75	---	85	---	---	---	---
S	---	---	49	---	67	---	---	---	---
S <sub>2</sub>	---	---	2.5	---	4	---	---	---	---
V <sub>1</sub>	---	---	M6x12.5(4)	---	M8x14 (4)	---	---	---	---

Dimensioni non impegnative

- Not binding dimensions

- unverbindliche Abmessungen

**ACCESSORI  
ACCESSORIES  
ZUBEHÖRE**

**AS**

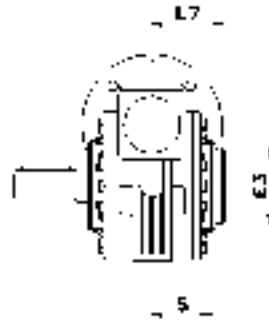
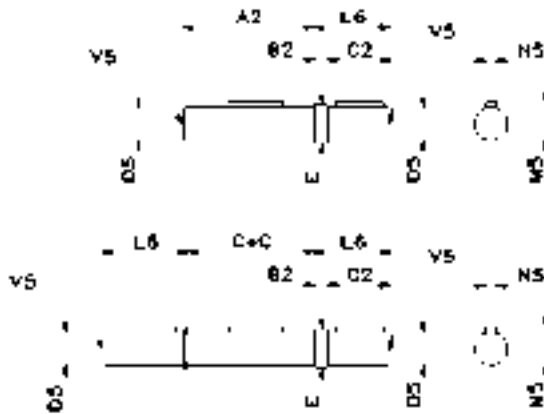

**ASC**

Protezione di sicurezza  
per AS  
Safety cap for AS  
Wellenschutz für AS

**AD**

**BR**

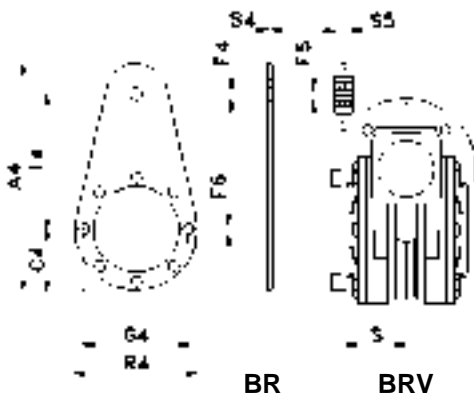

**SL**

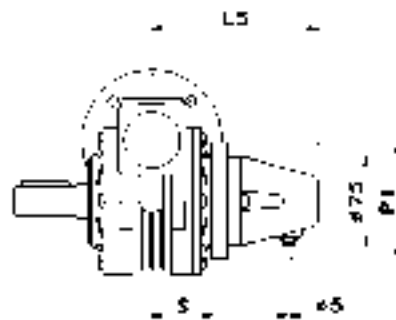

**TL**

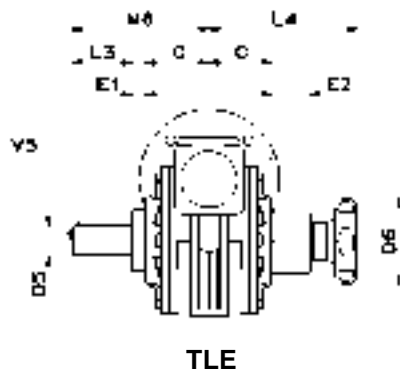

**VB**

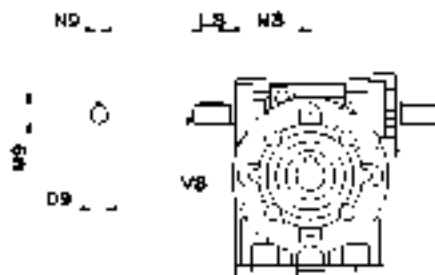

Litri / Litres

28	0.04
40	0.10
50	0.13
60	0.30
70	0.45
85	0.75
110	2.25

DIMENSIONI DI INGOMBRO  
OVERALL DIMENSIONS  
ABMESSUNGEN

RS	28	40	50	60	70	85	110	130	150
<b>AS &amp; AD</b> A <sub>2</sub>	58	80	95	117	117	119	153	177	207
B <sub>2</sub>	1	10	10	10	10	10	10	20	20
C	30	41	49	60	60	61	77.5	90	105
C <sub>2</sub>	30	40	45	50	60	70	100	110	110
D <sub>5</sub> (g6)	14	19 (18)	24 (25)	25	28	32 (35)	42	48	55
E	14	22	28	30	34	38	50	58	63
L <sub>6</sub>	31	50	55	60	70	80	100	130	130
M <sub>5</sub>	16	21.5	27	28	31	41	45	51.5	59
N <sub>5</sub>	5	6	8	8	8	10	12	14	16
V <sub>5</sub>	M5x10	M8x20	M8x20	M8x20	M8x20	M10x25	M10x25	---	---
<b>ASC</b> E <sub>3</sub>	42	55	62	62	72	90	120	---	---
L <sub>7</sub>	36	48.5	55.5	68.5	67	77	85	---	---
S	27.5	38.5	46.5	57	57	67	74	---	---
<b>BR &amp; BRV</b> A <sub>4</sub>	138	168	185	235	295	313	388	---	---
C <sub>4</sub>	38	43	60	55	65	75	100	---	---
F <sub>4</sub>	10.5	10.5	10.5	10.5	10.5	20.5	20.5	---	---
F <sub>5</sub>	10	10	10	10	10	20	20	---	---
F <sub>6</sub>	7	7	9	9	9	12	13	---	---
G <sub>4</sub>	55	60	70	80	95	110	130	---	---
I <sub>4</sub>	80	100	100	150	150	200	250	---	---
R <sub>4</sub>	65	75	85	95	115	130	165	---	---
S <sub>4</sub>	4	4	4	6	6	6	6	---	---
S <sub>5</sub>	15	15	15	20	20	25	25	---	---
<b>SL</b> L <sub>5</sub>	100	110	120	130	130	140	155	---	---
P <sub>1</sub>	77	88	100	110	132	160	200	---	---
S	27.5	38.5	46.5	57	57	67	74	---	---
<b>TLE</b> D <sub>6</sub>	52	70	70	70	80	100	100	---	---
E <sub>1</sub>	10	12	12	15	14	19	24	---	---
E <sub>2</sub>	28	37	31	40	46	57	71	---	---
L <sub>3</sub>	30	40	50	50	60	70	80	---	---
L <sub>4</sub>	94	116	118	128	146	168	201	---	---
M <sub>6</sub>	70	93	111	125	134	150	181	---	---
<b>TLI</b> D <sub>(H7)</sub>	14	19	24	25	28	32	42	---	---
D <sub>2</sub>	40	56	71	71	80	90	125	---	---
D <sub>3</sub>	14.2 x 20	19.5 x 20.5	24.5 x 28	25.5 x 26	28.5 x 22	32.5 x 27	42.5 x 38.5	---	---
L	45	61.5	77	86.5	89	94	109	---	---
M <sub>1</sub>	15.4*	21.8	27.3	27.3*	31.3	35.3	45.3	---	---
N <sub>1</sub> (H9)	5	6	8	8	8	10	12	---	---
<b>VB</b> D <sub>9</sub>	9	11	14	19	19	24	28	---	---
L <sub>8</sub>	20	23	30	40	40	50	60	---	---
M <sub>8</sub>	43	55	65	77	84	106.5	145	---	---
M <sub>9</sub>	10.2	12.5	16	22.5	22.5	27	31	---	---
N <sub>9</sub>	3	4	5	6	6	8	8	---	---
V <sub>8</sub>	M4x10	M4x10	M6x15	M8x20	M8x20	M8x20	M8x20	---	---
<p>* = Chiavetta ribassata - Undersized key - Passfedernut mit geringerer Tiefe  D<sub>5</sub> (..) = Diametro a richiesta - Diameter on demand - Durchmesser auf Anfrage</p>									

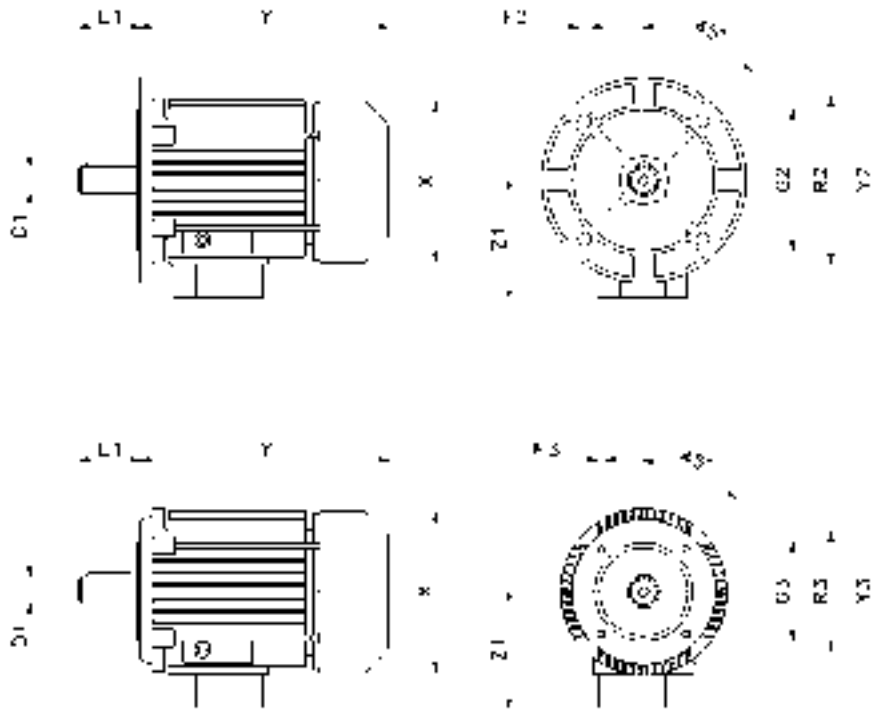

IEC MOTOR	56	63	71	80	90 S / L	100 - 112	132	160 M / L
D <sub>1(j6)</sub>	9	11	14	19	24	28	38	42
F <sub>2</sub>	7	9	9	11	11	14	14	18
F <sub>3</sub>	6	6	7	7	9	9	11	12
G <sub>2(j6)</sub>	80	95	110	130	130	180	230	250
G <sub>3(j6)</sub>	50	60	70	80	95	110	130	180
M <sub>3</sub>	10.4	12.8	16.3	21.8	27.3	31.3	41.3	45.3
N <sub>3</sub>	3	4	5	6	8	8	8	8
R <sub>2</sub>	100	115	130	165	165	215	265	300
R <sub>3</sub>	65	75	85	100	115	130	165	215
X	110	123	140	159	176	195	258	315
Y	168	185	215	238	255 / 280	309	368	478 / 522
Y <sub>2</sub>	120	140	160	200	200	250	300	350
Y <sub>3</sub>	80	90	105	120	140	160	200	250
Z <sub>1</sub>	108	110	121	138	149	160	192	220

Dimensioni non impegnative

- Not binding dimensions

- unverbindliche Abmessungen

**REVERSIBILITÀ E IRREVERSIBILITÀ  
BACK-DRIVING AND SELF-LOCKING  
UMKEHRBARKEIT UND SELBSTHEHMUNG**

Azionando al contrario un riduttore a vite senza fine con la ruota come organo motore, il rendimento è inferiore a quello di un azionamento con vite motrice e, agendo sui dati di progetto, il rendimento può essere ridotto a zero, ottenendo la irreversibilità dell'ingranamento.

When back-driving a worm gear set using the worm wheel as input, the efficiency is lower than forward-driving and, by varying the design data, back-drive efficiency can be reduced to zero obtaining a self-locking, or irreversible, gear set.

Wird das Schneckengetriebe über die Abtriebswelle angetrieben, ist der Wirkungsgrad des Getriebes schlechter als bei Antrieb über die Eingangswelle. Dabei kann in Abhängigkeit von der Verzahnung der Wirkungsgrad bis Null reduziert sein, was eine auftretende Selbsthemmung bis hin zur vollständigen Blockierung zur Folge hat.

In questo azionamento al contrario, l'attrito interno tende a bloccare l'ingranamento e, quanto maggior coppia è applicata alla ruota motrice, tanto più l'attrito d'ingranamento aumenta proporzionalmente ostacolando la rotazione.

When back-driving the worm gear, internal friction tends to lock the mesh, and the bigger the applied torque is, the more mesh friction increases proportionally augmenting the lockage at the same time.

Dieser Fall kann beispielsweise bei Abbremsung oder Senkung einer Last auftreten, wenn die Abtriebswelle durch die Last angetrieben wird.

L'esempio più ovvio è dato dalla frenatura o dall'abbassamento del carico per inerzia, dove la coppia esterna azionerà al contrario la vite.

The most obvious example is during braking or slowing-down where the inertial load will try to back-drive the wormshaft.

Ein Schneckengetriebe wird als selbsthemmend bezeichnet wenn der Spiralwinkel kleiner ist als der Reibungswinkel (Arkus-tangens vom Reibungskoeffizient).

Un riduttore a vite senza fine è considerato irreversibile quando l'angolo d'elica è inferiore all'angolo di attrito (arcotangente del coefficiente di attrito).

A worm gear is intended as a self-locking unit when the lead angle is less than the friction angle (arc tangent of friction coefficient).

Der Verzahnungseingriff ist dynamisch, auch wenn die Eingriffsgeschwindigkeit Null ist, da Vibrationen auf ein nicht drehendes Rad eine Bewegung hervorrufen können.

Il contatto sulla dentatura è dinamico anche quando la velocità d'ingranamento è zero, in quanto le vibrazioni su un ingranaggio non rotante possono originare il moto nella zona di contatto.

Tooth contact is dynamic even when the mesh velocity is zero, as vibrations in a non-rotating gearset can induce motion in the tooth contact.

Empfohlen wird, als Sicherheitsfaktor, die Wahl eines Spiralwinkels von 3° als Bedingung einer maximalen Selbsthemmung und von 10° als Bedingung einer geringen Selbsthemmung, wie aus der folgenden Tabelle ersichtlich wird.

Si consiglia come fattore di sicurezza la scelta di un angolo d'elica di 3° quale condizione di massima irreversibilità e di 10° quale condizione di minima irreversibilità, secondo la tabella delle relazioni fra angolo d'elica ed irreversibilità.

To provide a safety factor, a 3° lead angle is recommended for full self-locking condition, and 10° lead angle for poor self-locking condition, according to the table of relations between lead angle and self-locking.

Elica Lead angle Spiralwinkel	Irreversibilità	Self-locking	Selbsthemmung
$\beta > 20^\circ$	Reversibilità piena	Full reversibility	Volle Umkehrbarkeit
$10^\circ < \beta < 20^\circ$	Reversibilità elevata	High reversibility	Hohe Umkehrbarkeit
$5^\circ < \beta < 10^\circ$	Reversibilità buona Irreversibilità scarsa	Good reversibility Poor self-locking	Gute Umkehrbarkeit Schwache Selbsthemmung
$3^\circ < \beta < 5^\circ$	Reversibilità scarsa Irreversibilità buona	Poor reversibility Good self-locking	Schwache Umkehrbarkeit Gute Selbsthemmung
$1^\circ < \beta < 3^\circ$	Irreversibilità piena	Full self-locking	Volle Selbsthemmung

## DATI DI DENTATURA E SENSO DI ROTAZIONE GEARING DATA AND DIRECTION OF ROTATION VERZÄHNUNGSDATEN UND DREHRICHTUNGEN

	i =	7	10	15	20	28	40	49	56	70	80	100
<b>RS28</b>	$m_x$	1.50	1.40	1.40	1.10	1.50	1.10	0.90	0.75	0.60	0.55	0.45
	$\beta$	23°11'	16°41'	11°18'	10°23'	6°06'	5°14'	4°19'	3°03'	2°27'	2°37'	2°20'
	$Z_1$	4	3	2	2	1	1	1	1	1	1	1
<b>RS40</b>	$m_x$	2.10	2.00	2.00	1.50	2.10	1.50	1.25	1.10	0.90	0.80	0.65
	$\beta$	21°36'	16°41'	11°18'	8°31'	5°39'	4°17'	3°48'	3°25'	3°01'	2°51'	2°38'
	$Z_1$	4	3	2	2	1	1	1	1	1	1	1
<b>RS50</b>	$m_x$	2.70	2.50	2.50	1.90	2.70	1.90	1.60	1.40	1.10	1.00	0.80
	$\beta$	23°52'	16°41'	11°18'	5°59'	6°19'	4°31'	4°14'	3°42'	2°44'	2°51'	2°17'
	$Z_1$	4	3	2	2	1	1	1	1	1	1	1
<b>RS60</b>	$m_x$	3.30	3.10	3.10	2.40	3.30	2.40	2.00	1.70	1.40	1.20	1.00
	$\beta$	25°33'	19°0'	12°55'	11°18'	6°49'	5°42'	5°11'	3°55'	3°38'	2°51'	2°51'
	$Z_1$	4	3	2	2	1	1	1	1	1	1	1
<b>RS70</b>	$m_x$	3.90	3.60	3.60	2.80	3.90	2.80	2.30	2.00	1.60	1.40	1.15
	$\beta$	26°51'	18°38'	12°40'	11°18'	7°12'	5°42'	4°48'	4°05'	3°16'	2°51'	2°38'
	$Z_1$	4	3	2	2	1	1	1	1	1	1	1
<b>RS85</b>	$m_x$	4.70	4.40	4.40	3.40	4.70	3.40	2.80	2.50	2.00	1.74	1.40
	$\beta$	26°05'	19°09'	13°02'	11°18'	6°58'	5°52'	4°52'	4°45'	3°48'	3°14'	2°40'
	$Z_1$	4	3	2	2	1	1	1	1	1	1	1
<b>RS110</b>	$m_x$	6.10	5.80	5.80	4.40	6.10	4.40	3.60	3.20	2.60	2.30	1.80
	$\beta$	26°22'	20°43'	14°09'	11°18'	7°04'	5°42'	4°43'	4°29'	3°54'	3°39'	2°34'
	$Z_1$	4	3	2	2	1	1	1	1	1	1	1
<b>RS130</b>	$m_x$	7.25	6.90	6.85	5.35	7.25	5.30	4.35	4.00	3.15	2.70	2.25
	$\beta$	26°57'	21°20'	14°06'	13°05'	7°14'	6°18'	5°18'	6°20'	4°33'	3°30'	3°40'
	$Z_1$	4	3	2	2	1	1	1	1	1	1	1
<b>RS150</b>	$m_x$	8.25	8.00	8.15	6.20	8.45	6.25	5.10	4.60	3.60	3.15	2.60
	$\beta$	25°33'	21°48'	16°22'	13°24'	7°35'	7°07'	5°48'	6°11'	4°17'	3°45'	3°43'
	$Z_1$	4	3	2	2	1	1	1	1	1	1	1

$m_x$  = Modulo assiale      - Axial module      - Axialmodul  
 $Z_1$  = N. principi          - Number of starts      - Steigungen  
 $\beta$  = Angolo d'elica (dx)      - Lead angle (rh)      - Spiralwinkel (rx)  
 $20^\circ$  = Angolo di pressione      - Pressure angle      - Eingriffswinkel

**RS**

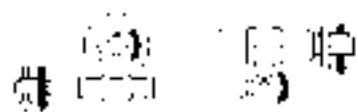
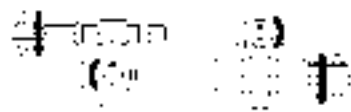

**RA**

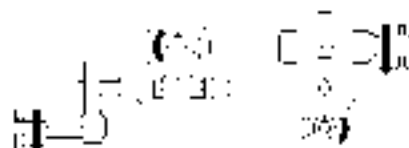
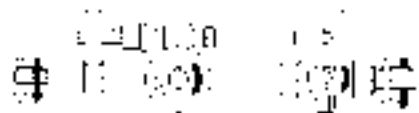

**RS/RS**

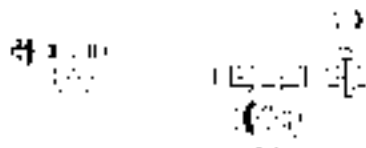

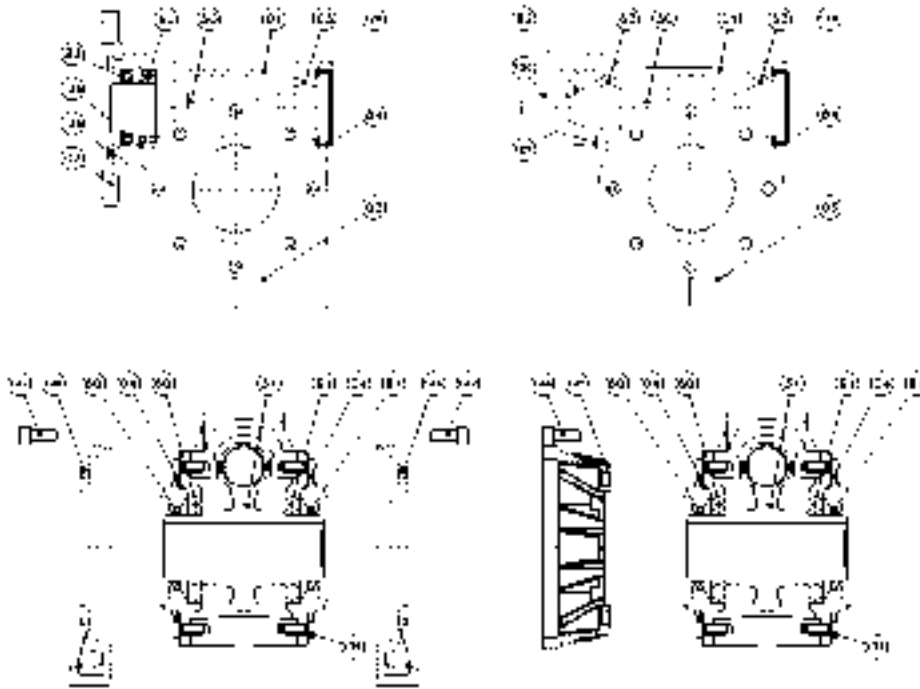

1	Carcassa	1	Housing	1	Gehäuse
3	Coperchio Laterale (S)	3	Side Cover (S)	3	Seitendeckel (S)
4	Coperchio Laterale (PC)	4	Side Cover (PC)	4	Seitendeckel (PC)
7	Flangia Entrata	7	Input Flange	7	Eingangsflansch
30	Vite senza fine RS	30	Wormshaft RS	30	Schneckenwelle RS
31	Ruota	31	Wormwheel	31	Schneckenrad
50	Vite senza fine FRS	50	Wormshaft FRS	50	Schneckenwelle FRS
60	Cuscinetto Ruota	60	Wormwheel Bearing	60	Lager
61	Cuscinetto Ruota	61	Wormwheel Bearing	61	Lager
62	Cuscinetto Anteriore Vite	62	Wormshaft Front Bearing	62	Lager
63	Cuscinetto Posteriore Vite	63	Wormshaft Rear Bearing	63	Lager
80	Paraolio Ruota	80	Wormwheel Oilseal	80	Wellendichtring
81	Paraolio Ruota	81	Wormwheel Oilseal	81	Wellendichtring
82	Paraolio Vite	82	Wormshaft Oilseal	82	Wellendichtring
84	Tappo RCA Posteriore	84	Plain Rear Oilseal	84	Abdeckkappe RCA
100	Chiavetta Vite RS	100	Wormshaft Key RS	100	Passfeder RS
125	Seeger Anteriore Vite	125	Wormshaft Front Circlip	125	Seegerring
126	Seeger Posteriore Vite (i)	126	Wormshaft Rear Circlip (i)	126	Seegerring (i)
135	Vite Coperchio Laterale	135	Side Cover Screw	135	Schraube
136	Vite Flangia Entrata	136	Input Flange Screw	136	Schraube
144	Vite Flangia Uscita F	144	Output Flange F Screw	144	Schraube F
145	Flangia Uscita	145	Output Flange	145	Ausgangsflansch
146	Piede Riportato (S)	146	Bolted Footed Cover (S)	146	Seitendeckel (S)

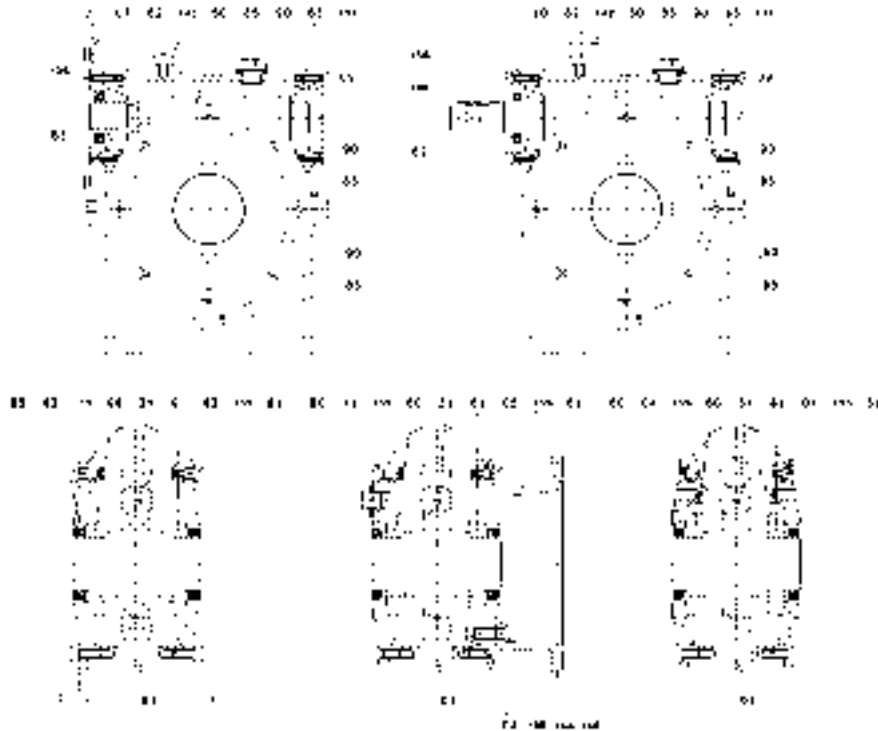

1	Carcassa	1	Housing	1	Gehäuse
3	Coperchio Laterale S	4	Side Cover S	4	Seitendeckel S
4	Coperchio Laterale PC	4	Side Cover PC	4	Seitendeckel PC
5	Coperchio Laterale FL	5	Side Cover FL	5	Seitendeckel FL
7	Flangia Entrata	7	Input Flange	7	Eingangsflansch
9	Coperchio Posteriore Vite	9	Wormshaft Rear Cover	9	Hintere Abdeckung
10	Coperchio anteriore vite RS	10	Wormshaft Front Cover RS	10	Vorderdeckel RS
11	Coperchio Laterale FO	11	Side Cover FO	11	Seitendeckel FO
30	Vite RT	30	Wormshaft RT	30	Schneckenwelle RT
31	Ruota	31	Wormwheel	31	Schneckenrad
50	Vite FRT	50	Wormshaft FRT	50	Schneckenwelle FRT
60	Cuscinetto Ruota	60	Wormwheel Bearing	60	Lager
61	Cuscinetto Ruota	61	Wormwheel Bearing	61	Lager
62	Cuscinetto Anteriore Vite	62	Wormshaft Front Bearing	62	Lager
63	Cuscinetto Posteriore Vite	63	Wormshaft Rear Bearing	63	Lager
80	Paraolio Ruota	80	Wormwheel Oilseal	80	Wellendichtring
81	Paraolio Ruota	81	Wormwheel Oilseal	81	Wellendichtring
82	Paraolio Vite	82	Wormwheel Oilseal	82	Wellendichtring
85	Tappo Olio	85	Oil Plug	85	Öl Entluftschraube
90	Guarnizione Tappo Olio	90	Oil Plug gasket	90	Dichtung Entluftschraube
100	Chiavetta Entrata RS	100	Wormshaft Key RS	100	Passfeder RS
135	Vite Coperchio Laterale	135	Side Cover Screw	135	Schraube
136	Vite Flangia Entrata	136	Input Flange Screw	136	Schraube
137	Vite Coperchio Posteriore	137	Wormshaft Rear Cover Screw	137	Schraube
142	Golfare	142	Eyebolt	142	Aufhängeöse
144	Vite Flangia Uscita F	144	Output Flange F Screw	144	Schraube F
145	Flangia Uscita F	145	Output Flange F	145	Seitendeckel F



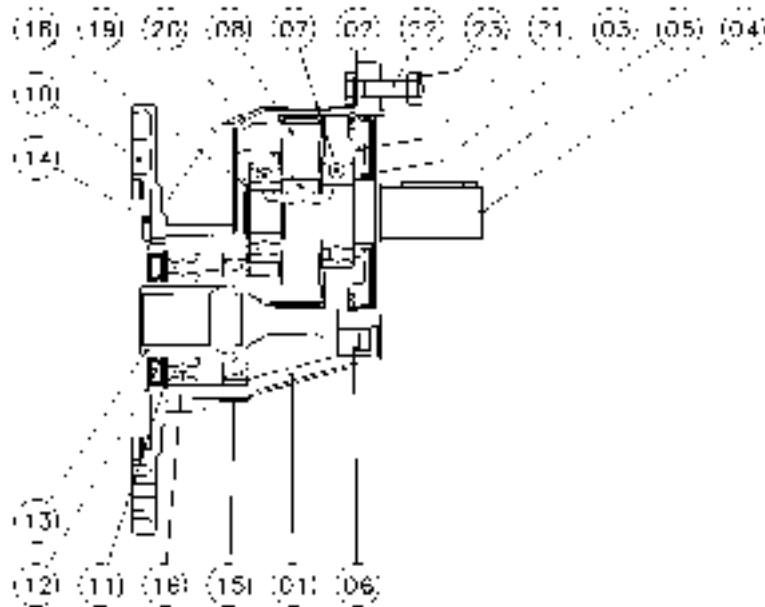

1	Carcassa	1	Housing	1	Gehäuse
2	Seeger (i)	2	Circlip (i)	2	Seegerring (i)
3	Paraolio Uscita	3	Output Oilseal	3	Wellendichtring
4	Albero Uscita	4	Output Shaft	4	Ausgangswelle
5	Chiavetta Albero Uscita	5	Output Shaft Key	5	Passfeder Ausgangswelle
6	Tappo	6	Plug	6	Verschlussschraube
7	Cuscinetto Anteriore Ruota	7	Wheel Front Bearing	7	Lager
8	Ruota	8	Wheel	8	Stirnrad
10	Flangia Entrata	10	Input Flange	10	Eingangsflansch
11	Seeger Entrata (i)	11	Input Circlip (i)	11	Seegerring (i)
12	Paraolio Entrata	12	Input Oilseal	12	Wellendichtring
13	Pignone	13	Pinion	13	Eingangsritzel
14	Vite Flangia Entrata	14	Input Flange Screw	14	Schraube Eingangsflansch
15	Cuscinetto Posteriore Pignone	15	Pinion Rear Bearing	15	Lager
16	Cuscinetto Anteriore Pignone	16	Pinion Front Bearing	16	Lager
18	Seeger Albero Uscita (e)	18	Output Shaft Circlip (e)	18	Seegerring (a)
19	Cuscinetto Posteriore Ruota	19	Wheel Rear Bearing	19	Lager
20	Chiavetta Ruota	20	Wheel Key	20	Passfeder
21	Supporto	21	Holder	21	Abstützung
22	Vite	22	Screw	22	Schraube
23	Dado	23	Nut	23	Mutter

**RS / RS**

ELENCO PARTI  
PART LIST  
EINZELTEILE

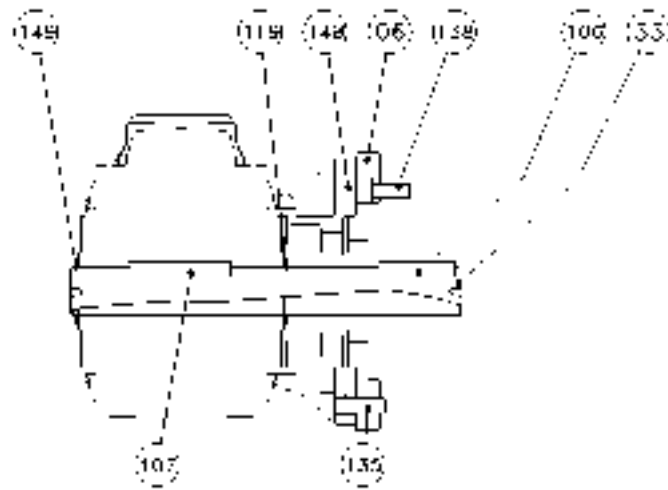

6	Flangia Entrata 2° Riduttore	6	2 <sup>nd</sup> Gearbox Input Flange	6	Eingangsflansch 2. Getriebe
33	Albero Collegamento	33	Adapter Shaft	33	Einsteckwelle
106	Chiavetta Entrata 2° Riduttore	106	2 <sup>nd</sup> Gearbox Input Key	106	Passfeder 2. Getriebe
107	Chiavetta Uscita 1° Riduttore	107	1 <sup>st</sup> Gearbox Output Key	107	Passfeder 1. Getriebe
119	Seeger (e)	119	Circlip (e)	119	Seeger (e)
135	Vite	135	Screw	135	Schraube
138	Vite	138	Screw	138	Schraube
148	Flangia Uscita 1° Riduttore	148	1 <sup>nd</sup> Gearbox Output Flange	148	Ausgangsflansch 1. Getriebe
149	Seeger (e)	149	Circlip (e)	149	Seeger (e)

## TLI - TLE 28 - 110

ELENCO PARTI  
PART LIST  
EINZELTEILE

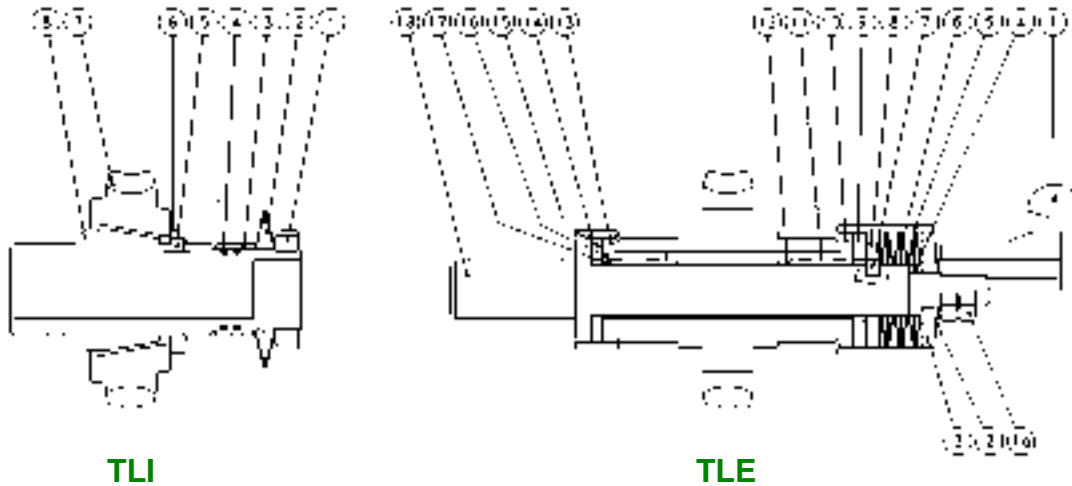

### TLI

1	Ghiera	1	Ring Nut	1	Ringmutter
2	Molla a Tazza	2	Belville Spring	2	Tellerfeder
3	Bussola	3	Bush	3	Hülse
4	Guarnizione OR	4	Oilseal OR	4	Dichtung OR
5	Linguetta	5	Key	5	Passfeder
6	Anello	6	Thrust Collar	6	Druckring
7	Ruota	7	Wormwheel	7	Schneckenrad
8	Albero Uscita Cavo	8	Hollow Output Shaft	8	Ausgangshohlwelle

### TLE

1 / 1a	Volantino / Dado e Controdado	1 / 1a	Locking Knob / Nut and Lock Nut	1 / 1a	Handrad / Einstellmutter
2	Molla a Tazza	2	Belville Spring	2	Tellerfeder
3	Anello	3	Locking Ring	3	Druckring
4	Spessore di Regolazione	4	Adjustment Shim	4	Ausgleichsring
5	Protezione Posteriore	5	Rear Cover	5	hintere Abdeckung
6	Molla a Tazza	6	Belville Spring	6	Tellerfeder
7	Linguetta	7	Key	7	Passfeder
8	Anello di Spinta	8	Thrust Collar	8	Druckring
9	Frizione Posteriore	9	Rear Friction Ring	9	hinterer Reibring
10	Anello di spinta	10	Thrust Collar	10	Druckring
11	Linguetta	11	Key	11	Passfeder
12	Boccola Posteriore	12	Rear Bush	12	hintere Hülse
13	Anello di Spinta	13	Thrust Collar	13	Druckring
14	Protezione Anteriore	14	Front Cover	14	vordere Abdeckung
15	Frizione Anteriore	15	Front Friction Ring	15	vorderer Reibring
16	Linguetta	16	Key	16	Passfeder
17	Boccola Anteriore	17	Front Bush	17	vordere Hülse
18	Albero Uscita Semplice	18	Single Output Shaft	18	Ausgangswelle, einseitig

**Estratto delle ISTRUZIONI DI USO E MANUTENZIONE  
Abstract of OPERATION AND MAINTENANCE INSTRUCTIONS  
Zusammenfassung der BETRIEBS- UND WARTUNGSANWEISUNGEN**

I riduttori e i variatori di velocità non ricadono nel campo di applicazione della Direttiva Macchine, art.1(2) e non possono essere messi in servizio finché la macchina nella quale devono essere incorporati, sia stata dichiarata conforme all'art. 4(2), all. II(B) delle Direttive Macchine 98/37/CEE/22.6.98 e, solo per l'Italia, al DL 459/24.7.96.

**Installazione**

Accertarsi che il gruppo da installare abbia le caratteristiche atte a svolgere la funzione richiesta e che la posizione di montaggio sia coerente con quanto ordinato. Tali caratteristiche sono deducibili dalla targhetta di identificazione apposta sul riduttore. Effettuare la verifica della stabilità del montaggio affinché non si verifichino vibrazioni o sovraccarichi durante il funzionamento.

**Funzionamento**

Il riduttore può essere collegato per rotazione oraria o antioraria. Arrestare immediatamente il riduttore in caso di funzionamento difettoso o di rumorosità anomala, rimuovere il difetto o ritornare l'apparecchio alla fabbrica per una adeguata revisione. Se la parte difettosa non viene sostituita, anche altre parti possono venire danneggiate con conseguenti ulteriori danneggiamenti e più scarsa possibilità di risalire alle cause.

**Manutenzione**

Sebbene i gruppi siano provati con funzionamento senza carico prima della spedizione, è consigliabile non usarli a carico massimo durante le prime 20-30 ore di funzionamento affinché le parti interne possano adattarsi reciprocamente. I riduttori sono spediti già riempiti con olio sintetico a lunga durata e, se occorre sostituire o rabboccare il lubrificante, non mescolare oli a base sintetica con oli a base minerale.

**Movimentazione**

In caso di sollevamenti con paranco, utilizzare posizioni di aggancio sulla struttura della carcassa, golfari ove esistenti, fori dei piedi o sulle flange, evitando tutte le parti mobili.

**Verniciatura**

Qualora il gruppo subisca una verniciatura successiva, è necessario proteggere accuratamente gli anelli di tenuta, i piani di accoppiamento e gli alberi sporgenti.

**Conservazione prolungata a magazzino**

Per permanenze maggiori di 3 mesi, è consigliata la applicazione di antiossidanti su alberi esterni e piani lavorati, e di grasso protettivo sui labbri dei paraolio.

**Gestione Ambientale del prodotto**

In conformità alla Certificazione Ambientale ISO 14001, vengono suggerite le seguenti indicazioni per lo smaltimento del nostro prodotto:

- i componenti del gruppo che vengono rottamati debbono essere consegnati a centri di raccolta autorizzati per i materiali metallici;
- gli oli ed i lubrificanti raccolti dal gruppo devono essere smaltiti consegnandoli ai Consorzi Oli esausti;
- gli imballi a corredo dei gruppi (pallet, cartone, carta, plastica, ecc.) vanno avviati per quanto più possibile al recupero/riciclo, consegnandoli a ditte autorizzate per le singole classi di rifiuto.

Variable speed and reduction gearboxes are not part of the field of application of the Machinery Directive, art.1(2), and they must not be put into service until the machinery into which they are to be incorporated, has been declared in conformity with the provision of art.4(2), annex II(B) of Machinery Directives 98/37/CEE/22.6.98 and for Italy only, of DL 459/24.7.96.

**Installation**

Check if the unit to be installed, is properly selected to perform the required function and that its mounting position complies with the order. The name plate reports such information. Check mounting stability to run the unit without vibrations or overloads.

**Running**

The unit may be connected for clockwise or counter-clockwise rotation. The unit must be stopped as soon as defective running or unexpected noise occur, remove the faulty part or return the unit to the factory for checking. If the faulty part is not replaced, other parts can also be affected, causing more severe damage and making the identification of initial cause more difficult.

**Maintenance**

Although the units are no-load run tested in the factory before despatch, it is recommended not to run them at maximum load for the first 20-30 running hours to allow the proper running-in. The gearboxes are delivered already filled with long-life synthetic oil and, in case of replacement or topping, do not mix with mineral lubricants.

**Handling**

When hoisting, use relevant housing locations or eyebolts if provided, or foot or flange holes. Never hoist on any moving part.

**Painting**

Carefully protect oilseals, coupling faces and shafts when units are re-painted.

**Long-term storage**

For storages longer than 3 months, apply anti-oxidants onto shafts and machined surfaces, and protective grease on oilseal lips.

**Product's Environmental Management**

In conformity with Environmental Certification ISO 14001, we recommend the following to dispose of our products:

- scraped components of the units to deliver to authorized centres for metal object collection;
- oils and lubricants drained from the units to deliver to Exhausted Oil Unions;
- packages (pallets, carton boxes, paper, plastic, etc.) to lead into regeneration/recycling circuits as far as possible, by delivering separate waste classes to authorized companies.

Varvel-Getriebe und Variatoren fallen nicht unter den Geltungsbereich der Maschinenrichtlinien, Artikel 1 (2): Sie dürfen jedoch nicht in Betrieb gesetzt werden, bevor sich nicht Maschinen, in die sie eingebaut werden, mit Artikel 4 (2), Anhang II (B) der Maschinenrichtlinien 98/37/CEE/22.6.98, und (nur für Italien) DL 459/24.07.96, in Übereinstimmung befinden.

**Aufstellung**

Vor der Aufstellung ist zu prüfen, dass die Antriebseinheit in Bezug auf die Betriebsbedingungen richtig ausgewählt wurde und die Einbaulage mit der Bestellung übereinstimmt. Angaben hierüber sind auf dem Typenschild zu finden. Die Stützkonstruktion für die Getriebe ist so stabil auszuführen, dass keine Schwingungen oder Überlastungen auftreten, eventuell sind elastische Kupplungen oder Drehmomentbegrenzer zu verwenden.

**Inbetriebnahme**

Die Antriebseinheit kann in beiden Drehrichtungen eingesetzt werden. Die Einheit müsst sofort angehalten werden, wenn ein unzulässiger Lauf oder unerwartete Geräusche auftreten. Das fehlerhafte Teil ist zu ersetzen oder die Einheit ist zur Überprüfung einzuschicken. Falls das fehlerhafte Teil nicht ersetzt wird, kann dies zu weiteren Schäden an anderen Bauteilen führen, was eine Feststellung der Ursachen sehr schwierig machen kann.

**Wartung**

Obwohl die Einheiten vor der Auslieferung im Leerlauf getestet wurden, ist es ratsam sie in den ersten 20-30 Stunden nicht mit Vollast zu betreiben, um ein einwandfreies Einlaufen zu gewährleisten. Die Einheiten werden entsprechend den Angaben auf dem Typenschild mit synthetischem Schmierstoff lebensdauer geschmiert ausgeliefert. Bei einem eventuellen Ölwechsel oder Nachfüllen darf der Schmierstoff nicht mit Mineralöl vermischt werden.

**Handhabung und Transport**

Beim Heben und Transport ist auf standsichere Lage und sorgfältige Befestigung geeigneter Hebevorrichtungen zu achten. Bewegliche Teile dürfen nicht zum Anheben benutzt werden.

**Anstrich**

Beim Erneuern oder dem zusätzlichen Aufbringen eines Anstriches sind die Dichtungen, Kupplungssitze und Wellen sorgfältig zu schützen.

**Langzeitlagerung**

Die Einlagerung der Einheiten muss trocken und staubfrei erfolgen. Bei einer Einlagerungszeit über 3 Monate sind bearbeitete Flächen (außer Aluminium) und Wellen mit Rostschutzmitteln zu besprühen, Dichtlippen sind mit Fett zu schützen.

**Entsorgung**

In Übereinstimmung mit ISO 14001 weisen wir darauf hin, im Falle des Verschrottens die einzelnen Metallteile getrennt zu behandeln und Schmiermittel bei den befugten Stellen zu entsorgen. Verpackungen sollten soweit möglich wieder verwendet werden.