

PRODUCT DATASHEET

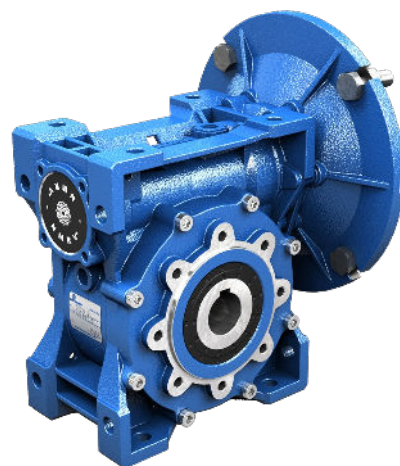

WORMGEARREDUCER

DATE 14.08.2023

CHARACTERISTIC	VALUE
Regulations	No
Worm	PAM NMRV
Size	025
Ratio (i)	20,0
Input Dim.	Ø80x9 (IEC56 B14)
Hollow Output Shaft Dim.	Ø11
Double-Extended Worm Shaft	No
Mounting Position	U
VI-Output Oil Seal	NBR-Nitrile
VI-Input Oil Seal	ACM-Polyacrylate
VI-Output Bearings	Ball Bearings
VI-Lubrication	Synthetic ISO VG320
Paint	Not Painted

Values expressed in [mm]

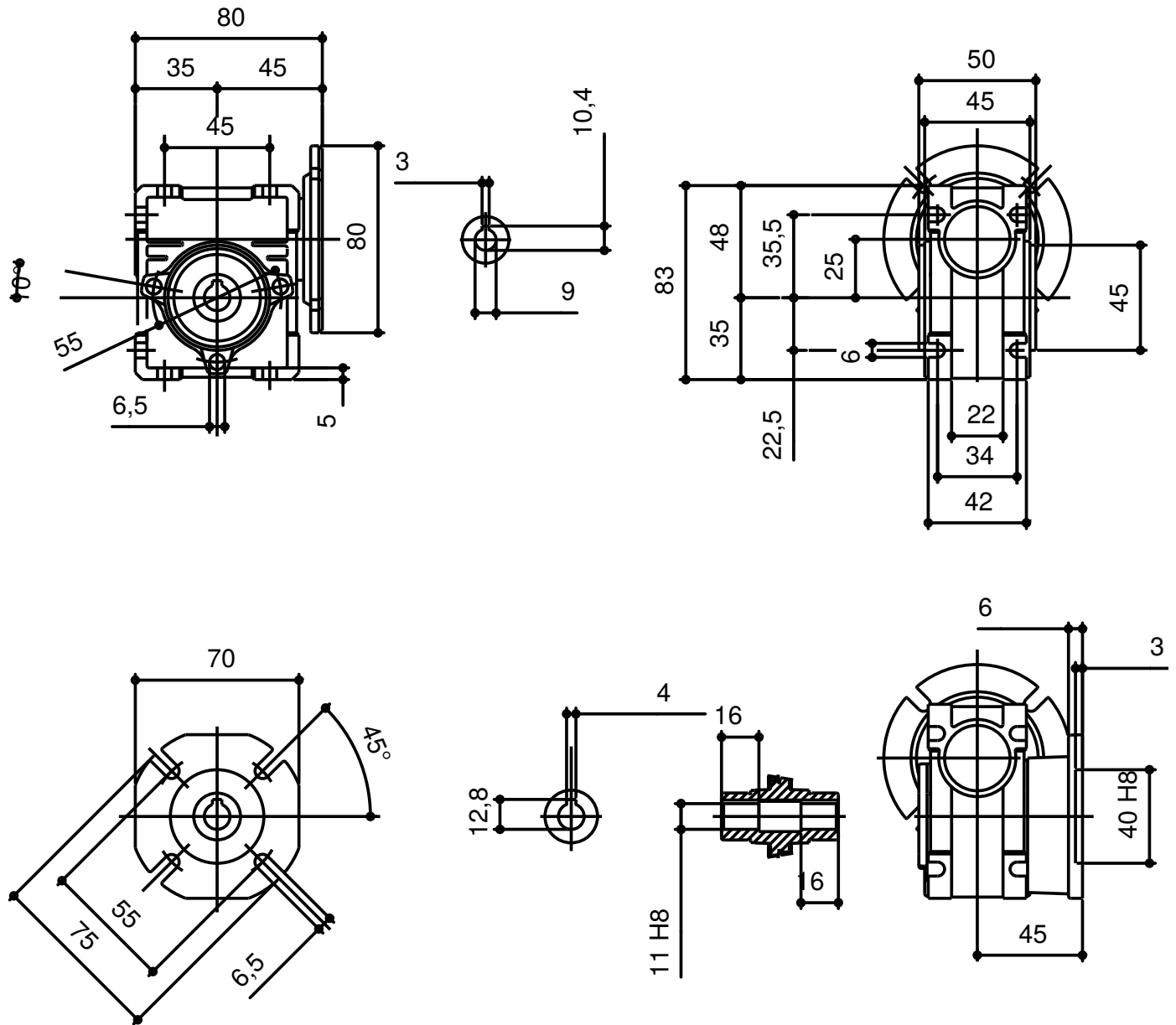

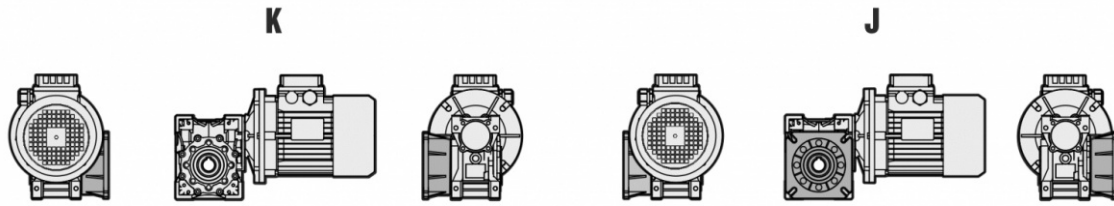

Unless specified otherwise, the reduction unit is supplied with the flange in pos. J referred to position B3.

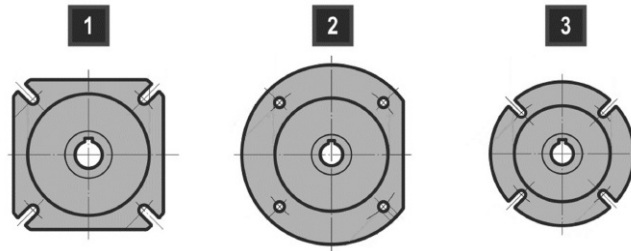

	NMRV - SW	NMRV - SW	NMRV - SW	NMRV-P - SW	NMRV-P - SW	NMRV-P - SW	SW	NMRV-P	NMRV	NMRV
	030	040	050	063	075	090	105	110	130	150
FA	1	1	1	1	1	1	1	1	1	1
FB	-	1	1	1	3	2	1	1	-	-
FC	-	2	2	2	-	3	-	-	-	-
FD	-	2	2	2	-	1	-	-	-	-
FE	-	-	-	3	-	-	-	-	-	-

ISW030

n1 [rpm]	Mn ₂ [Nm]	i	Pn ₁ [kW]	n2 [rpm]	Fr1 [N]	Fr2 [N]
500	23	20,00	0,09	25,0	210	1336
900	20	20,00	0,13	45,0	210	1098
1140	19	20,00	0,16	57,0	210	1015
1400	18	20,00	0,18	70,0	180	948
1750	17	20,00	0,21	88,0	179	880
2800	12	20,00	0,22	140,0	146	752

ISW040

n1 [rpm]	Mn ₂ [Nm]	i	Pn ₁ [kW]	n2 [rpm]	Fr1 [N]	Fr2 [N]
500	57	20,00	0,20	25,0	350	2570
900	48	20,00	0,30	45,0	350	2113
1140	46	20,00	0,35	57,0	350	1953
1400	43	20,00	0,40	70,0	350	1824
1750	41	20,00	0,47	88,0	350	1693
2800	29	20,00	0,51	140,0	204	1447

ISW050

n1 [rpm]	Mn ₂ [Nm]	i	Pn ₁ [kW]	n2 [rpm]	Fr1 [N]	Fr2 [N]
500	100	20,00	0,35	25,0	490	3528
900	83	20,00	0,51	45,0	490	2900
1140	80	20,00	0,61	57,0	490	2680
1400	78	20,00	0,71	70,0	490	2503
1750	74	20,00	0,85	88,0	490	2324
2800	53	20,00	0,94	140,0	417	1987

ISW063

n1 [rpm]	Mn ₂ [Nm]	i	Pn ₁ [kW]	n2 [rpm]	Fr1 [N]	Fr2 [N]
500	194	20,00	0,68	25,0	700	4611
900	163	20,00	0,99	45,0	700	3791
1140	154	20,00	1,14	57,0	700	3504
1400	146	20,00	1,30	70,0	700	3272
1750	138	20,00	1,53	88,0	700	3037
2800	104	20,00	1,80	140,0	556	2597

ISW075

n1 [rpm]	Mn ₂ [Nm]	i	Pn ₁ [kW]	n2 [rpm]	Fr1 [N]	Fr2 [N]
500	326	20,00	1,11	25,0	980	5443
900	268	20,00	1,58	45,0	980	4474
1140	250	20,00	1,84	57,0	980	4135
1400	236	20,00	2,09	70,0	980	3862
1750	221	20,00	2,42	88,0	980	3585
2800	173	20,00	2,94	140,0	935	3065

ISW090

n1 [rpm]	Mn ₂ [Nm]	i	Pn ₁ [kW]	n2 [rpm]	Fr1 [N]	Fr2 [N]
500	517	20,00	1,71	25,0	1270	6022
900	429	20,00	2,47	45,0	1270	4951
1140	410	20,00	2,92	57,0	1270	4576
1400	391	20,00	3,37	70,0	1270	4273
1750	371	20,00	3,97	88,0	1270	3967
2800	260	20,00	4,33	140,0	1120	3391

ISW105

n1 [rpm]	Mn ₂ [Nm]	i	Pn ₁ [kW]	n2 [rpm]	Fr1 [N]	Fr2 [N]
500	836	20,00	2,70	25,0	1270	7610
900	670	20,00	3,76	45,0	1270	6256
1140	632	20,00	4,43	57,0	1270	5782
1400	596	20,00	5,08	70,0	1270	5399
1750	566	20,00	5,99	88,0	1270	5012
2800	401	20,00	6,61	140,0	1270	4285

NRV030

n1 [rpm]	Mn ₂ [Nm]	i	Pn ₁ [kW]	n2 [rpm]	Fr1 [N]	Fr2 [N]
500	23	20,00	0,09	25,0	210	1336
900	20	20,00	0,13	45,0	210	1098
1140	19	20,00	0,16	57,0	210	1015
1400	18	20,00	0,18	70,0	180	948
1750	17	20,00	0,21	88,0	179	880
2800	12	20,00	0,22	140,0	146	752

PERFORMANCES

NRV040

n1 [rpm]	Mn ₂ [Nm]	i	Pn ₁ [kW]	n2 [rpm]	Fr1 [N]	Fr2 [N]
500	57	20,00	0,20	25,0	350	2570
900	48	20,00	0,30	45,0	350	2113
1140	46	20,00	0,35	57,0	350	1953
1400	43	20,00	0,40	70,0	350	1824
1750	41	20,00	0,47	88,0	350	1693
2800	29	20,00	0,51	140,0	204	1447

NRV050

n1 [rpm]	Mn ₂ [Nm]	i	Pn ₁ [kW]	n2 [rpm]	Fr1 [N]	Fr2 [N]
500	100	20,00	0,35	25,0	490	3528
900	83	20,00	0,51	45,0	490	2900
1140	80	20,00	0,61	57,0	490	2680
1400	78	20,00	0,71	70,0	490	2503
1750	74	20,00	0,85	88,0	490	2324
2800	53	20,00	0,94	140,0	417	1987

NRV-P063

n1 [rpm]	Mn ₂ [Nm]	i	Pn ₁ [kW]	n2 [rpm]	Fr1 [N]	Fr2 [N]
500	194	20,00	0,68	25,0	700	4611
900	163	20,00	0,99	45,0	700	3791
1140	154	20,00	1,14	57,0	700	3504
1400	146	20,00	1,30	70,0	700	3272
1750	138	20,00	1,53	88,0	700	3037
2800	104	20,00	1,80	140,0	556	2597

NRV-P075

n1 [rpm]	Mn ₂ [Nm]	i	Pn ₁ [kW]	n2 [rpm]	Fr1 [N]	Fr2 [N]
500	326	20,00	1,11	25,0	980	5443
900	268	20,00	1,58	45,0	980	4474
1140	250	20,00	1,84	57,0	980	4135
1400	236	20,00	2,09	70,0	980	3862
1750	221	20,00	2,42	88,0	980	3585
2800	173	20,00	2,94	140,0	935	3065

NRV-P090

n1 [rpm]	Mn ₂ [Nm]	i	Pn ₁ [kW]	n2 [rpm]	Fr1 [N]	Fr2 [N]
500	517	20,00	1,71	25,0	1270	6022
900	429	20,00	2,47	45,0	1270	4951
1140	410	20,00	2,92	57,0	1270	4576
1400	391	20,00	3,37	70,0	1270	4273
1750	371	20,00	3,97	88,0	1270	3967
2800	260	20,00	4,33	140,0	1120	3391

NRV-P110

n1 [rpm]	Mn ₂ [Nm]	i	Pn ₁ [kW]	n2 [rpm]	Fr1 [N]	Fr2 [N]
500	863	20,00	2,79	25,0	1700	7610
900	725	20,00	4,07	45,0	1700	6256
1140	685	20,00	4,80	57,0	1700	5782
1400	644	20,00	5,49	70,0	1700	5399
1750	612	20,00	6,47	88,0	1700	5012
2800	483	20,00	7,96	140,0	1485	4285

NRV130

n1 [rpm]	Mn ₂ [Nm]	i	Pn ₁ [kW]	n2 [rpm]	Fr1 [N]	Fr2 [N]
500	1230	20,00	3,93	25,0	2100	9953
900	1040	20,00	5,77	45,0	2100	8182
1140	975	20,00	6,85	57,0	2100	7562
1400	910	20,00	7,67	70,0	2100	7062
1750	864	20,00	9,10	88,0	2100	6556
2800	660	20,00	10,87	140,0	1912	5605

NRV150

n1 [rpm]	Mn ₂ [Nm]	i	Pn ₁ [kW]	n2 [rpm]	Fr1 [N]	Fr2 [N]
500	1820	20,00	5,81	25,0	2800	13607
900	1500	20,00	8,32	45,0	2800	11186
1140	1500	20,00	10,53	57,0	2800	10338
1400	1300	20,00	10,95	70,0	2674	9654
1750	1235	20,00	13,01	88,0	2673	8962
2800	980	20,00	15,96	140,0	2289	7663

MOUNTING POSITIONS

The mounting position of the gear unit identifies its space orientation. B3 mounting position, as from a technical point of view, ensures lower oil splash, better lubrication and less heating.

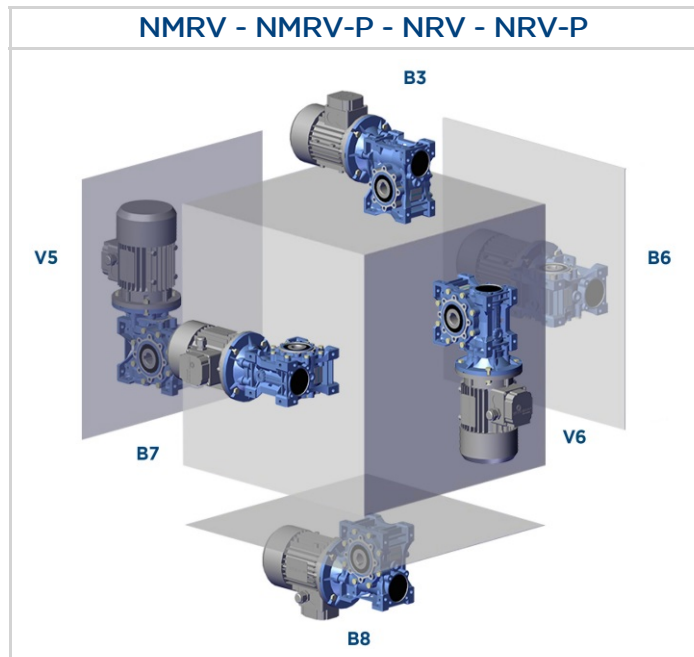

Execution

NMRV/NMRV-P+NMRV/NMRV-P - NRV/NRV-P+NMRV/NMRV-P

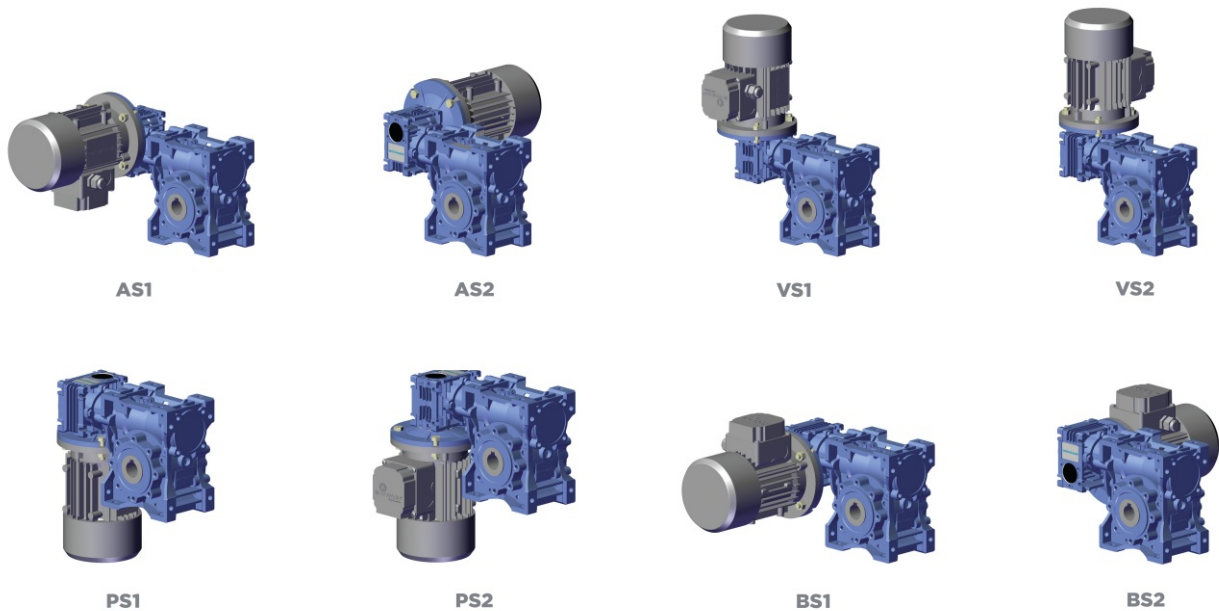

- The gear reducers size 025 - 030 - 040 - 050 - 063 - 075 - 090 - 105 - 110 - 130 - 150 are supplied complete with lubricant, synthetic oil, ENI TELIUM VSF. They can be mounted in any position envisaged in the catalogue, except for NMRV-P/SW 090 - 110 and NRV-P/ISW 075-090-110 for which you must to specify the mounting position.
- For sizes 130 and 150 it is necessary to specify the position, otherwise the gear reducers are supplied with the quantity of oil relating to pos. B3.
- Only reduction units 130 and 150 are fitted with breather, level and oil drainage plugs.
- The pre-stage helical modules are supplied complete with life-long lubricant, synthetic oil, ENI TELIUM VSF. Lubrication is separated from that of the worm gear reducers.

It is recommended, after installation, to replace the closed plug used for transportation with the supplied breather plug.

Quantity of oil in litres -

NMRV	025	030	040	050	130	150
B3	0,02	0,04	0,08	0,15	4,5	7
B8					3,3	5,1
B6-B7					3,5	5,4
V5					4,5	7
V6					3,3	5,1

NMRV-P	063	075	090	110
B3	0,33	0,55	1,15	1,6
B8				
B6-B7				
V5				
V6				

SW	030	040	050	063	075	090	105
B3	0,04	0,08	0,15	0,3	0,55	1	1,6
B8							
B6-B7							
V5							
V6							

HW	HW030		HW040	
	NMRV-P063	NMRV-P075	NMRV-P090	NMRV-P110
B3-B6-B7-B8-V5-V6	0,06	0,09	0,11	0,12

H	A31
B3-B5	0,07

NMRV	063	075	090	105	110
B3	0,3	0,55	1	1,6	3
B8					2,2
B6-B7					2,5
V5					3
V6					2,2

DIRECTION OF ROTATION

The worm screw rotation is right-handed.

DIRECTION OF ROTATION - HIGH SPEED SHAFT

NMRV - NRV - SW - ISW



MOUNTING POSITION **B3**

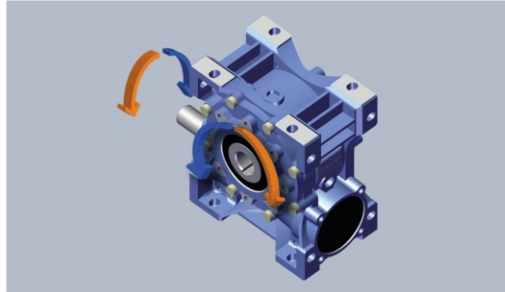

MOUNTING POSITION **B8**

NMRV + NMRV - SW + SW - NRV + NMRV - ISW + SW

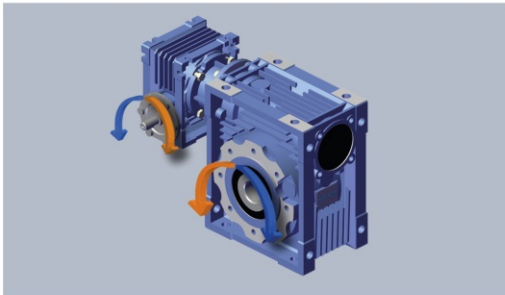

MOUNTING POSITION **AS1**

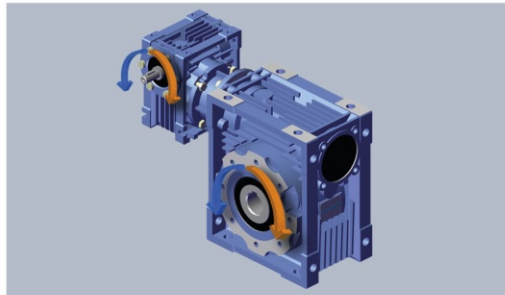

MOUNTING POSITION **BS1**