



Customer information packet

CECP84117T-4

30HP, 1180RPM, 3PH, 60HZ, 326TC, TEFC, F1

ELECTRIC MOTOR WHOLESAL.COM

Class - CLI GP A,B,C,D

Division - Division II

Specifications

Enclosure	TEFC
Frame	326TC
Frame Material	Iron
Frequency	60.00 Hz
Motor Letter Type	Three Phase
Output @ Frequency	30.000 HP @ 60 HZ
Phase	3
Synchronous Speed @ Frequency	1200 RPM @ 60 HZ
Voltage @ Frequency	460.0 V @ 60 HZ
XP Class and Group	CLIGP A,B,C,D
XP Division	Division II
Agency Approvals	CCSA US CSA EEV UR
Ambient Temperature	40 °C
Auxillary Box	No Auxillary Box
Auxillary Box Lead Termination	None
Base Indicator	Rigid
Bearing Grease Type	Polyrex EM (-20F +300F)
Blower	None
Constant Torque Speed Range	1
Current @ Voltage	38.000 A @ 460.0 V
Design Code	B
Drip Cover	No Drip Cover
Duty Rating	CONT
Efficiency @ 100% Load	93.0 %
Electrically Isolated Bearing	Not Electrically Isolated
Enclosure Modification	841
Feedback Device	NO FEEDBACK
Heater Indicator	No Heater
High Voltage Full Load Amps	38.0 a
Insulation Class	F

Part detail

Revision	D
Type	AC
Mech. spec.	
Base	
Status	PRD/A
Elec. spec.	12WGZ195
Layout	12LY-000-140
Eff. date	04-07-2022
CD Diagram	CD0006
Poles	06
Leads	3#8
Proprietary	False
Created date	01-15-2019

Inverter Code	Inverter Duty
IP Rating	IP56
KVA Code	G
Lifting Lugs	Standard Lifting Lugs
Locked Bearing Indicator	Locked Bearing
Max Speed	1800 rpm
Motor Lead Termination	Ring Terminals
Motor Standards	NEMA
Motor Type	1268M
Mounting Arrangement	F1
Number of Poles	6
Overall Length	30.66 IN
Power Factor	80
Product Family	Chem Process S/P 32-8 IEEE 841
Pulley Face Code	C-Face
Rodent Screen	None
Service Factor	1.15
Shaft Diameter	2.125 IN
Shaft Ground Indicator	No Shaft Grounding
Shaft Rotation	Reversible
Speed	1180 rpm
Speed Code	Single Speed
Starting Method	Direct on line
Thermal Device - Winding	None
Vibration Sensor Indicator	No Vibration Sensor
Winding Thermal 1	None
Winding Thermal 2	None
XP Temp Code	T3

Nameplate

NP3190

STK.NO.	CECP84117T-4	P/N		ENCLOSURE	TEFC
SPEC.	12-0000-0418	CC	010A	FRAME	326TC
HP	30	CLASS	F	HZ	60
RPM	1180	RPM MAX	1800	ODE BRG	6312
VOLT	460	PH	3	DE BRG	6312
AMP	38	DES	B	D.E. BRG.	60BC03X30X
RATING	40C AMB-CONT	KVA-CODE	G	O.D.E. BRG.	60BC03X30X
NEMA-NOM-EFF	93	MOTOR WEIGHT	640	GREASE	POLYREX EM
G.MIN.EFF	91.7	MAX. KVAR	9.9	BLANK	
TEMP CODE	T3	# OF ROTOR BARS	42	SER.F.	1.15
TEMP =	200	# OF STATOR SLOTS	54	IP	56
CT HZ FROM	1	PF	80	INV.TYPE	PWM
HTR-VOLTS		INVERTER-TEMP-CODE	200		
HTR-AMPS		C HP FR	60	C HP TO	90
HTR-WATTS		CT HZ TO	60		
MAX. SPACE HEATER TEMP.				VT HZ FROM	0
				VT HZ TO	60

Parts list

Part number	Description	Quantity
SA365128	SA 12-0000-0418	1.000 ea
RA354501	RA 12-0000-0418	1.000 ea
LB1115N	LABEL,LIFTING DEVICE (ON ROLLS)	1.000 ea
LB1119N	WARNING LABEL	1.000 ea
LC0006	CONNECTION LABEL	1.000 ea
LB1449	DIV-2/NEC WARNING LABEL	1.000 ea
NP3190	SS IEEE841 INV DIV-2 UL CSA-C US EEV	1.000 ea
85XU0407S04	4X1/4 U DRIVE PIN STAINLESS	4.000 ea
MN416A01	TAG-INSTAL-MAINT no wire (2200bx) 4/22	1.000 ea
WD1000B48	T&B D73, RING TERMINAL 8 AWG 3/8 STUD	3.000 ea
WD1000B19	TERMINAL BURNDY L250HP	1.000 ea
HW1001A38	LOCKWASHER 3/8, ZINC PLT .688 OD, .382 I	1.000 ea
80XN3816A12	SET SCREW,HEX SOCKET CUP POINT,3/8-16 X	4.000 ea
12FH1002A15GP6	FAN COVER, MACH, W/PRIMER W/MG1025N19	1.000 ea
HW1001A50	LOCKWASHER 1/2, ZINC PLT,.879 OD, .509 I	4.000 ea
XY5013A12	NUT,1/2-13,HEX,STEEL,ZINCPLATED	4.000 ea
09FN3001B03SP	EXTERNAL FAN, PLASTIC (COMES W/SCREW FRO	1.000 ea
HW2500A25	WOODRUFF KEY USA #1008 #BLOW CARBON STEE	1.000 ea
MJ1000A02	GREASE, POLYREX EM EXXON	0.200 lb
10XN3816K08	3/8-16 X .50 HEX HD CAP SCREW GRADE 5	1.000 ea
12EP1111A02GP6	FR ENDPLATE, MACH W/EPOXY PRIMER & RELIA	1.000 ea
HA3400A32	STUD, 1/2-13 X 7.38	4.000 ea
HW1001A50	LOCKWASHER 1/2, ZINC PLT,.879 OD, .509 I	4.000 ea
HW4601A55	INPRO/SEAL #1698-A-M0022-0 VBXX 312 BRG/	1.000 ea
HW5100A15	W4997-050 WVY WSHR (WB)	1.000 ea
HW4500A20	1/8NPT SL PIPE PLUG	1.000 ea
HA4017A02	.125X2.50 GREASER EXTENS.F/S	1.000 ea
HA4017A01	1/8 X 4 GREASE EXT (F/S)	1.000 ea
HW4019A01	PIPE COUPLING 1/8 NPT,STEEL,ZINC COATING	1.000 ea
10XN3118K40	5/16-18 X 2.50" HEX HD, GRADE 5	4.000 ea
HA4051A00	PLASTIC CAP FOR GREASE FITTING	1.000 ea

HW4500A21	1618BALEMITE FITTING 825 UNIVERSAL	1.000 ea
HW4500A17	317400 ALEMITE GREASE RELIEF	1.000 ea
HA4002A03	#304 S.S. DRAIN FITTING, .125 NPT (.44 H	1.000 ea
HA4002A03	#304 S.S. DRAIN FITTING, .125 NPT (.44 H	1.000 ea
12EP1105A99P	PU EP, MACH, PLS, INPRO W/EPOXY PRIMER	1.000 ea
HW1001A50	LOCKWASHER 1/2, ZINC PLT,.879 OD, .509 I	4.000 ea
10XN5013K28	1/2-13 X 1.75 HEX HEAD MACH SCREW,GRAD	4.000 ea
HW4601A55	INPRO/SEAL #1698-A-M0022-0 VBXX 312 BRG/	1.000 ea
HW4500A20	1/8NPT SL PIPE PLUG	1.000 ea
10XN3118K40	5/16-18 X 2.50" HEX HD, GRADE 5	4.000 ea
HA4051A00	PLASTIC CAP FOR GREASE FITTING	1.000 ea
HW4500A03	GREASE FITTING, .125 NPT 1610(ALEMITE) 8	1.000 ea
HW4500A17	317400 ALEMITE GREASE RELIEF	1.000 ea
10CB1000A04P	KO BOX, MACH W/2.00 NPT W/EPOXY PRIMER	1.000 ea
09GS1010	GASKET, DWG, LEADWIRE SEPERATOR	1.000 ea
10XN3118K16	5/16-18 X 1' GRADE #5, STL, ZINC PLATE	4.000 ea
HW1001A31	LOCKWASHER 5/16, ZINC PLT.591 OD, .319 I	4.000 ea
WD1000B16	T&B CX70TN OR L70P TERMINAL LUG	1.000 ea
59XW2520G07	.25-20X.44,HEX SER WSHR,TAPTITE 2,GREEN	1.000 ea
10CB1503A01P	CONDUIT BOX LIPPED LID, MACH W/EPXY PRMR	1.000 ea
14GS1003	GASKET CONDUIT BOX LID, NEOP	1.000 ea
10XN2520K16	1/4-20 X 1" HX HD SCRW GRADE 5, ZINC P	4.000 ea
HW1001A25	LOCKWASHER 1/4, ZINC PLT .493 OD, .255 I	4.000 ea
MG1025N19	WILKOFAS, 778.50, RELIANCE BLUE-GREEN 8	0.125 ga
MJ5001A27	32220KN GRAY SEALER *MIN BUY 4 QTS=1GAL	0.031 qt
MJ5002A01	SILICON RUBBER SEALANT, 732CL 10.3 OZ TU	0.033 ea
MJ5002A01	SILICON RUBBER SEALANT, 732CL 10.3 OZ TU	0.025 ea
12PA1000	PACKAGING GROUP PRINT PK1024A07	1.000 ea
HW2501H33	KEY, 1/2 SQ X 3.875	1.000 ea
MJ5004A59	ADHESIVE LOCTITE #401 SURFACE INSENSITIV	0.010 ea

AC Induction Motor Performance Data

Record # 93177

Typical performance - not guaranteed values

Winding: 12WGZ195-R001		Type: 1268M		Enclosure: TEFC	
Nameplate Data			460 V, 60 Hz: Single Voltage Motor		
Rated Output (HP)	30	Full Load Torque	133.6 LB-FT		
Volts	460	Start Configuration	direct on line		
Full Load Amps	38	Breakdown Torque	343 LB-FT		
R.P.M.	1180	Pull-up Torque	154 LB-FT		
Hz	60	Phase	3	Locked-rotor Torque	189 LB-FT
NEMA Design Code	B	KVA Code	G	Starting Current	217 A
Service Factor (S.F.)	1.15		No-load Current	15 A	
NEMA Nom. Eff.	93	Power Factor	80	Line-line Res. @ 25°C	0.24434 Ω
Rating - Duty	40C AMB-CONT		Temp. Rise @ Rated Load	55°C	
S.F. Amps			Temp. Rise @ S.F. Load	68°C	
			Locked-rotor Power Factor	29.1	

Load Characteristics 460 V, 60 Hz, 30 HP

% of Rated Load	25	50	75	100	125	150	S.F.
Power Factor	45	67	76	80	81	81	81
Efficiency	90.6	93.5	93.8	93	92.4	91.1	92.8
Speed	1195.5	1190.7	1185.8	1180.5	1174.1	1166.3	1177
Line amperes	17.2	22.5	29.5	37.5	46.6	57	43

ABB Motors and Mechanical Inc.

WINDING # 12WGZ195

Typical performance - not guaranteed values.

30 HP 3 PH 60 HZ 1180 RPM 460 V 1268M

TORQUES (LB-FT): PO=343 PU=154 LR=189 LRA=217

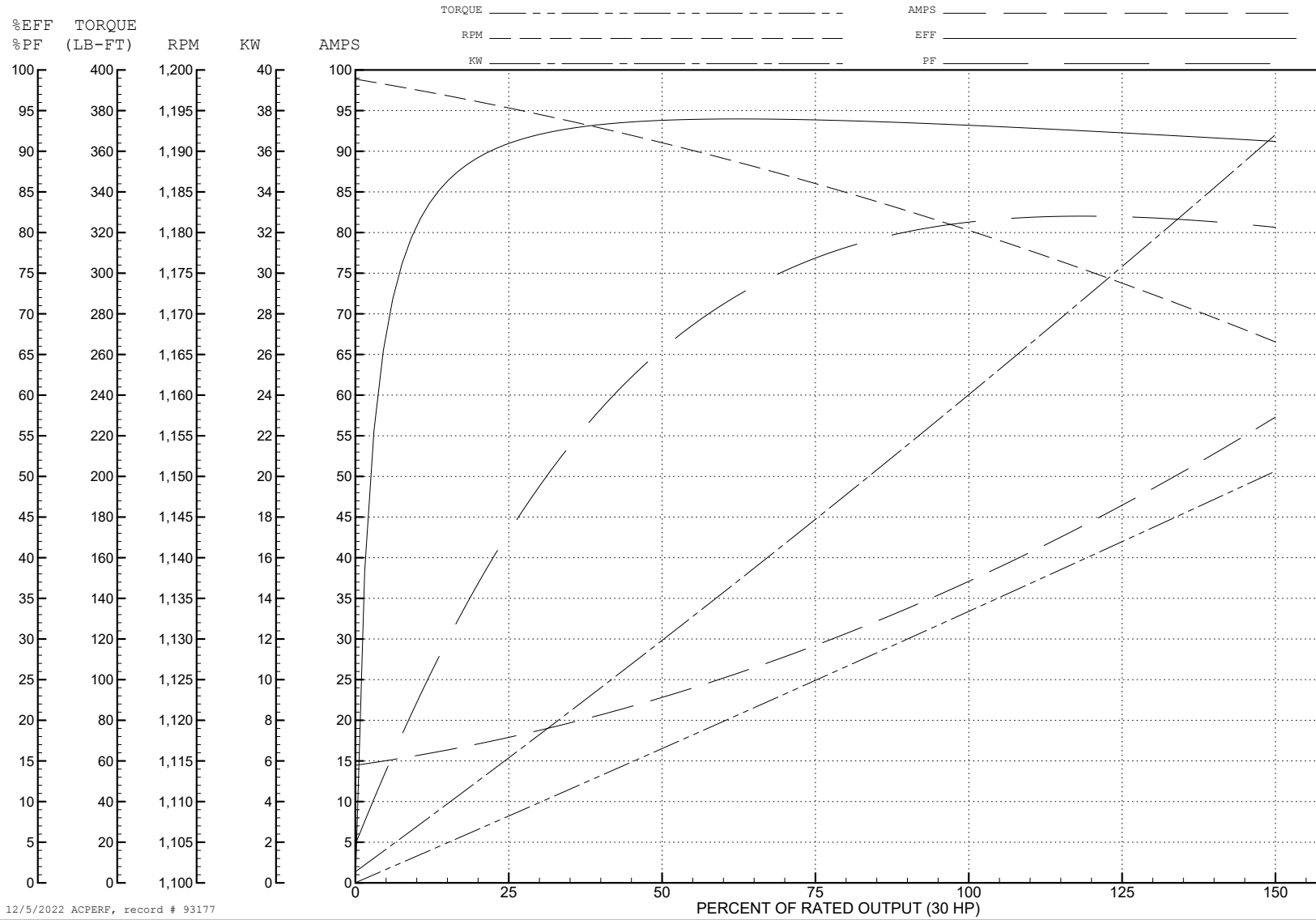

12/5/2022 ACPERF, record # 93177

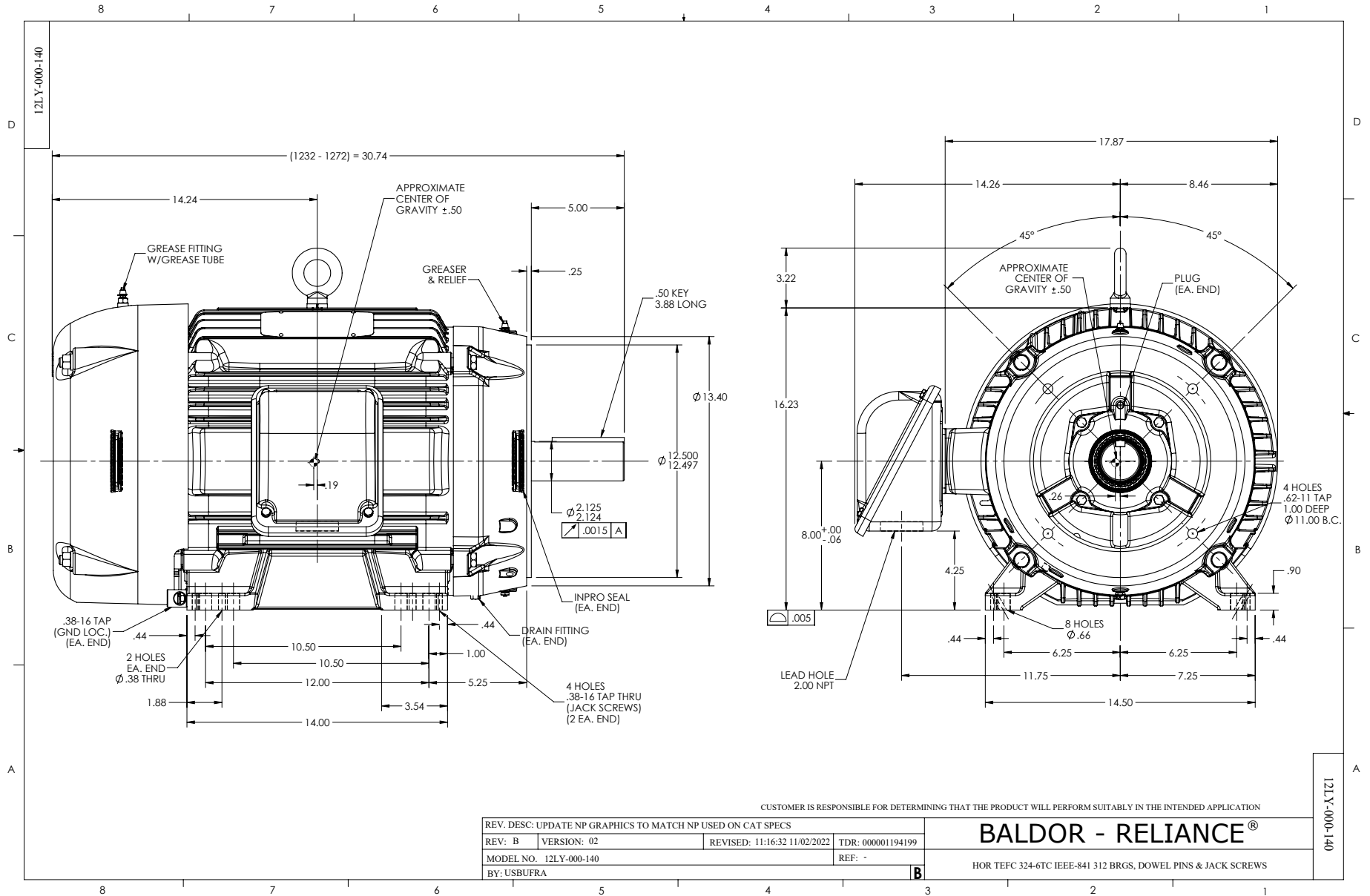

CD0006

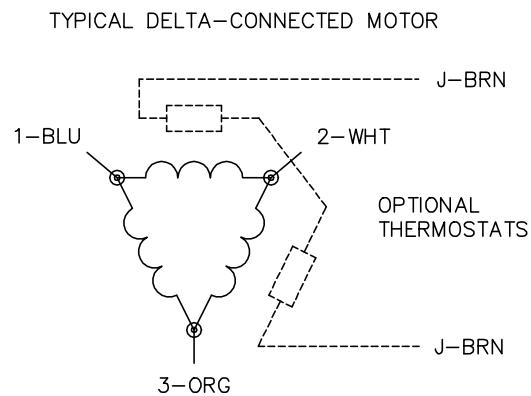
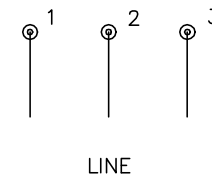
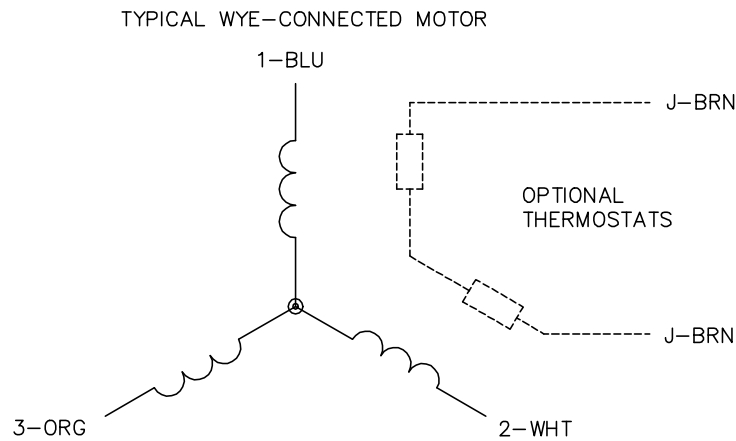

NOTES:

1. THREE LEAD MOTOR MAY BE EITHER WYE CONNECTED OR DELTA CONNECTED.
2. INTERCHANGE ANY TWO LINE LEADS TO REVERSE ROTATION.
3. OPTIONAL THERMOSTATS ARE PROVIDED WHEN SPECIFIED.
4. ACTUAL NUMBER OF INTERNAL PARALLEL CIRCUITS MAY VARY.
5. LEAD COLORS ARE OPTIONAL. LEADS MUST BE NUMBERED AS SHOWN.

CD0006

REV. DESC: ADD CLASS CONN00000007		
REV. LTR: E	VERSION: 01	TDR: 000001099922
FILE: \AAA\00005\141	REVISED: 10:24:49 02/19/2019	BY: ENBRIRO
MTL: -	© □	

BALDOR - RELIANCE®

3PH, SV, 3 LEADS, WYE OR DELTA CONNECTED

SH 1 of 1