



Customer information packet

CECP84104T-4

30HP, 1770RPM, 3PH, 60HZ, 286TC, TEFC, F1

ELECTRIC MOTOR WHOLESAL.COM

Class - CLI GP A,B,C,D

Division - Division II

Specifications

Enclosure	TEFC
Frame	286TC
Frame Material	Iron
Frequency	60.00 Hz
Motor Letter Type	Three Phase
Output @ Frequency	30.000 HP @ 60 HZ
Phase	3
Synchronous Speed @ Frequency	1800 RPM @ 60 HZ
Voltage @ Frequency	460.0 V @ 60 HZ
XP Class and Group	CLIGP A,B,C,D
XP Division	Division II
Agency Approvals	CCSA US CSA EEV UR
Ambient Temperature	40 °C
Auxillary Box	No Auxillary Box
Auxillary Box Lead Termination	None
Base Indicator	Rigid
Bearing Grease Type	Polyrex EM (-20F +300F)
Blower	None
Constant Torque Speed Range	1
Current @ Voltage	36.000 A @ 460.0 V
Design Code	B
Drip Cover	No Drip Cover
Duty Rating	CONT
Efficiency @ 100% Load	93.6 %
Electrically Isolated Bearing	Not Electrically Isolated
Enclosure Modification	841
Feedback Device	NO FEEDBACK
Heater Indicator	No Heater
High Voltage Full Load Amps	36.0 a
Insulation Class	F

Part detail

Revision	F
Type	AC
Mech. spec.	
Base	
Status	PRD/A
Elec. spec.	10WGZ438
Layout	10LY-000-170
Eff. date	11-21-2022
CD Diagram	CD0006
Poles	04
Leads	3#10
Proprietary	False
Created date	01-23-2019

Inverter Code	Inverter Duty
IP Rating	IP56
KVA Code	G
Lifting Lugs	Standard Lifting Lugs
Locked Bearing Indicator	Locked Bearing
Max Speed	2700 rpm
Motor Lead Termination	Ring Terminals
Motor Standards	NEMA
Motor Type	1060M
Mounting Arrangement	F1
Number of Poles	4
Overall Length	27.93 IN
Power Factor	84
Product Family	Chem Process S/P 32-8 IEEE 841
Pulley Face Code	C-Face
Rodent Screen	None
Service Factor	1.15
Shaft Diameter	1.875 IN
Shaft Ground Indicator	No Shaft Grounding
Shaft Rotation	Reversible
Speed	1770 rpm
Speed Code	Single Speed
Starting Method	Direct on line
Thermal Device - Winding	None
Vibration Sensor Indicator	No Vibration Sensor
Winding Thermal 1	None
Winding Thermal 2	None
XP Temp Code	T3C

Nameplate

NP3190

STK.NO.	CECP84104T-4	P/N		ENCLOSURE	TEFC
SPEC.	10-0000-0472	CC	010A	FRAME	286TC
HP	30	CLASS	F	HZ	60
RPM	1770	RPM MAX	2700	ODE BRG	6311
VOLT	460	PH	3	DES	B
AMP	35.6	DE BRG		D.E. BRG.	55BC03X30X
RATING	40C AMB-CONT	KVA-CODE	G	O.D.E. BRG.	55BC03X30X
NEMA-NOM-EFF	93.6	MOTOR WEIGHT	465	GREASE	POLYREX EM
G.MIN.EFF	92.4	MAX. KVAR	7.7	BLANK	
TEMP CODE	T3	# OF ROTOR BARS	40	SER.F.	1.15
TEMP =	200	# OF STATOR SLOTS	48	IP	56
CT HZ FROM	30	PF	84	INV.TYPE	PWM
HTR-VOLTS		INVERTER-TEMP-CODE	200		
HTR-AMPS		C HP FR	60	C HP TO	90
HTR-WATTS		CT HZ TO	60		
MAX. SPACE HEATER TEMP.				VT HZ FROM	30
				VT HZ TO	60

Parts list

Part number	Description	Quantity
SA365394	SA 10-0000-0472	1.000 ea
RA354778	RA 10-0000-0472	1.000 ea
LB1115N	LABEL,LIFTING DEVICE (ON ROLLS)	1.000 ea
LB1119N	WARNING LABEL	1.000 ea
LC0006	CONNECTION LABEL	1.000 ea
LB1449	DIV-2/NEC WARNING LABEL	1.000 ea
NP3190	SS IEEE841 INV DIV-2 UL CSA-C US EEV	1.000 ea
85XU0407S04	4X1/4 U DRIVE PIN STAINLESS	4.000 ea
MN416A01	TAG-INSTAL-MAINT no wire (2200bx) 4/22	1.000 ea
WD1000B49	T&B C73,RING TERMINAL 10-12 AWG 3/8 STUD	3.000 ea
WD1000B16	T&B CX70TN OR L70P TERMINAL LUG	1.000 ea
HW1001A25	LOCKWASHER 1/4, ZINC PLT .493 OD, .255 I	1.000 ea
80XN3816A12	SET SCREW,HEX SOCKET CUP POINT,3/8-16 X	4.000 ea
10FH1007A24LP5	FAN COVER W/1.00 SLOT @ 6:00	1.000 ea
HW1001A31	LOCKWASHER 5/16, ZINC PLT.591 OD, .319 I	3.000 ea
10XN3118K20	5/16-18 X 1 1/4 GRADE 5 STEEL ZC PLATED	3.000 ea
09FN3001D02	EXTERNAL FAN, PLASTIC (COMES W/SCREW FRO	1.000 ea
HW2500A25	WOODRUFF KEY USA #1008 #BLOW CARBON STEE	1.000 ea
MJ1000A02	GREASE, POLYREX EM EXXON	0.130 lb
10XN2520K06	1/4-20 X 3/8" HX HD SCREWGRADE 5, ZINC P	1.000 ea
10EP1110A02LP5	FR ENDPLATE, MACH W/PRIMER & PAINT	1.000 ea
10XN3816K28	3/8-16 X 1.75 HEX HD CAP SCREW, GRADE 5	4.000 ea
HW1001A38	LOCKWASHER 3/8, ZINC PLT .688 OD, .382 I	4.000 ea
HW4601A53	INPRO/SEAL VBXX FOR 311 BEARING/310 FRAM	1.000 ea
HW5100A13	W4627-047 WVY WSHR	1.000 ea
HA4017A02	.125X2.50 GREASER EXTENS.F/S	1.000 ea
HA4017A02	.125X2.50 GREASER EXTENS.F/S	1.000 ea
HW4019A01	PIPE COUPLING 1/8 NPT,STEEL,ZINC COATING	1.000 ea
10XN3118K40	5/16-18 X 2.50" HEX HD, GRADE 5	4.000 ea
HA4051A00	PLASTIC CAP FOR GREASE FITTING	1.000 ea
HW4500A21	1618BALEMITE FITTING 825 UNIVERSAL	1.000 ea

HW4500A17	317400 ALEMITE GREASE RELIEF	1.000 ea
HW4500A20	1/8NPT SL PIPE PLUG	1.000 ea
HA4002A03	#304 S.S. DRAIN FITTING, .125 NPT (.44 H	1.000 ea
10EP1305A116P	PU ENDPLATE, MACH W/INPRO SEAL & EPOXY P	1.000 ea
HW1001A38	LOCKWASHER 3/8, ZINC PLT .688 OD, .382 I	4.000 ea
10XN3816K28	3/8-16 X 1.75 HEX HD CAP SCREW, GRADE 5	4.000 ea
HW4601A53	INPRO/SEAL VBXX FOR 311 BEARING/310 FRAM	1.000 ea
10XN3118K40	5/16-18 X 2.50" HEX HD, GRADE 5	4.000 ea
HA4051A00	PLASTIC CAP FOR GREASE FITTING	1.000 ea
HW4500A03	GREASE FITTING, .125 NPT 1610(ALEMITE) 8	1.000 ea
HW4500A17	317400 ALEMITE GREASE RELIEF	1.000 ea
HW4500A20	1/8NPT SL PIPE PLUG	1.000 ea
HA4002A03	#304 S.S. DRAIN FITTING, .125 NPT (.44 H	1.000 ea
10CB1000A09P	KOBX, MACH W/1.50 NPT & PRIMER	1.000 ea
09GS1010	GASKET, DWG, LEADWIRE SEPERATOR	1.000 ea
10XN3118K16	5/16-18 X 1' GRADE #5, STL, ZINC PLATE	4.000 ea
HW1001A31	LOCKWASHER 5/16, ZINC PLT.591 OD, .319 I	4.000 ea
WD1000B16	T&B CX70TN OR L70P TERMINAL LUG	1.000 ea
59XW2520G07	.25-20X.44,HEX SER WSHR,TAPTITE 2,GREEN	1.000 ea
10CB1503A01P	CONDUIT BOX LIPPED LID, MACH W/EPXY PRMR	1.000 ea
14GS1003	GASKET CONDUIT BOX LID, NEOP	1.000 ea
10XN2520K16	1/4-20 X 1" HX HD SCRW GRADE 5, ZINC P	4.000 ea
HW1001A25	LOCKWASHER 1/4, ZINC PLT .493 OD, .255 I	4.000 ea
MG1025N19	WILKOFAS, 778.50, RELIANCE BLUE-GREEN 8	0.125 ga
MJ5001A27	32220KN GRAY SEALER *MIN BUY 4 QTS=1GAL	0.031 qt
MJ5001A14	DYNAPRO SEALANT, CP MTR VC#2508050 (603	0.033 ea
MJ5002A01	SILICON RUBBER SEALANT, 732CL 10.3 OZ TU	0.025 ea
10PA1000	PACKAGING GROUP COMBINED PRINT PK1023A06	1.000 ea
HW2501H28	KEY, 1/2 SQ X 3.250	1.000 ea
MJ5004A59	ADHESIVE LOCTITE #401 SURFACE INSENSITIV	0.010 ea

AC Induction Motor Performance Data

Record # 93188

Typical performance - not guaranteed values

Winding: 10WGZ438-R001		Type: 1060M	Enclosure: TEFC
Nameplate Data		460 V, 60 Hz: Single Voltage Motor	
Rated Output (HP)	30	Full Load Torque	88.64 LB-FT
Volts	460	Start Configuration	direct on line
Full Load Amps	36	Breakdown Torque	267 LB-FT
R.P.M.	1770	Pull-up Torque	116 LB-FT
Hz	60 Phase	Locked-rotor Torque	142 LB-FT
NEMA Design Code	B KVA Code	Starting Current	217.5 A
Service Factor (S.F.)	1.15	No-load Current	13.5 A
NEMA Nom. Eff.	93.6 Power Factor	Line-line Res. @ 25°C	0.234 Ω
Rating - Duty	40C AMB-CONT	Temp. Rise @ Rated Load	62°C
S.F. Amps		Temp. Rise @ S.F. Load	76°C
		Locked-rotor Power Factor	29.7
		Rotor inertia	4.77 lb-ft ²

Load Characteristics 460 V, 60 Hz, 30 HP

% of Rated Load	25	50	75	100	125	150	S.F.
Power Factor	48	71	80	84	85	85	83
Efficiency	91	94	94.3	93.6	93.7	92	93.4
Speed	1793	1787	1779	1772	1764	1753	1769
Line amperes	15.8	21.1	27.8	35.6	44	53.5	41.5

ABB Motors and Mechanical Inc.

WINDING # 10WGZ438

Typical performance - not guaranteed values.

30 HP 3 PH 60 HZ 1770 RPM 460 V 1060M

TORQUES (LB-FT): PO=267 PU=116 LR=142 LRA=217.5

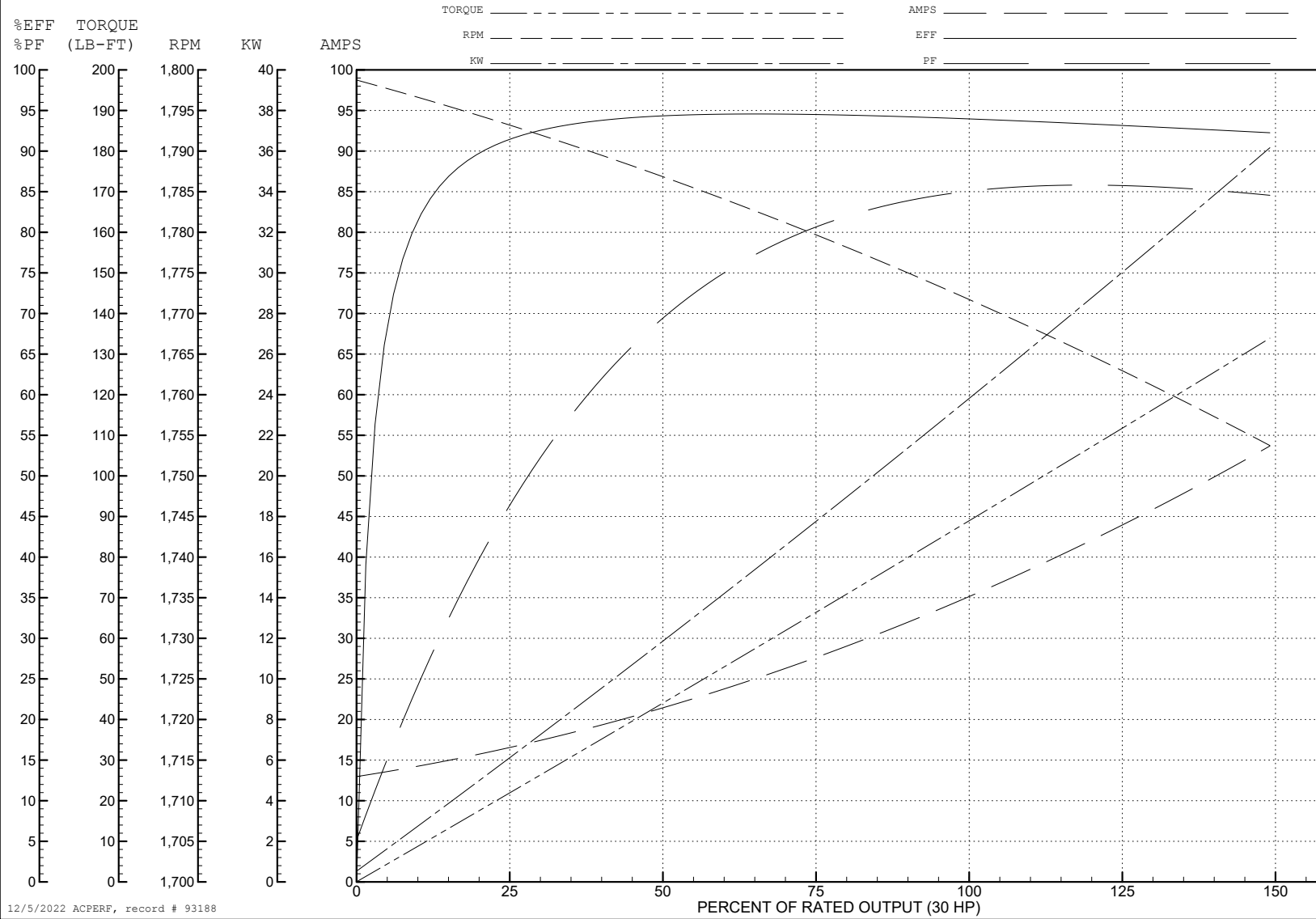

12/5/2022 ACPERF, record # 93188

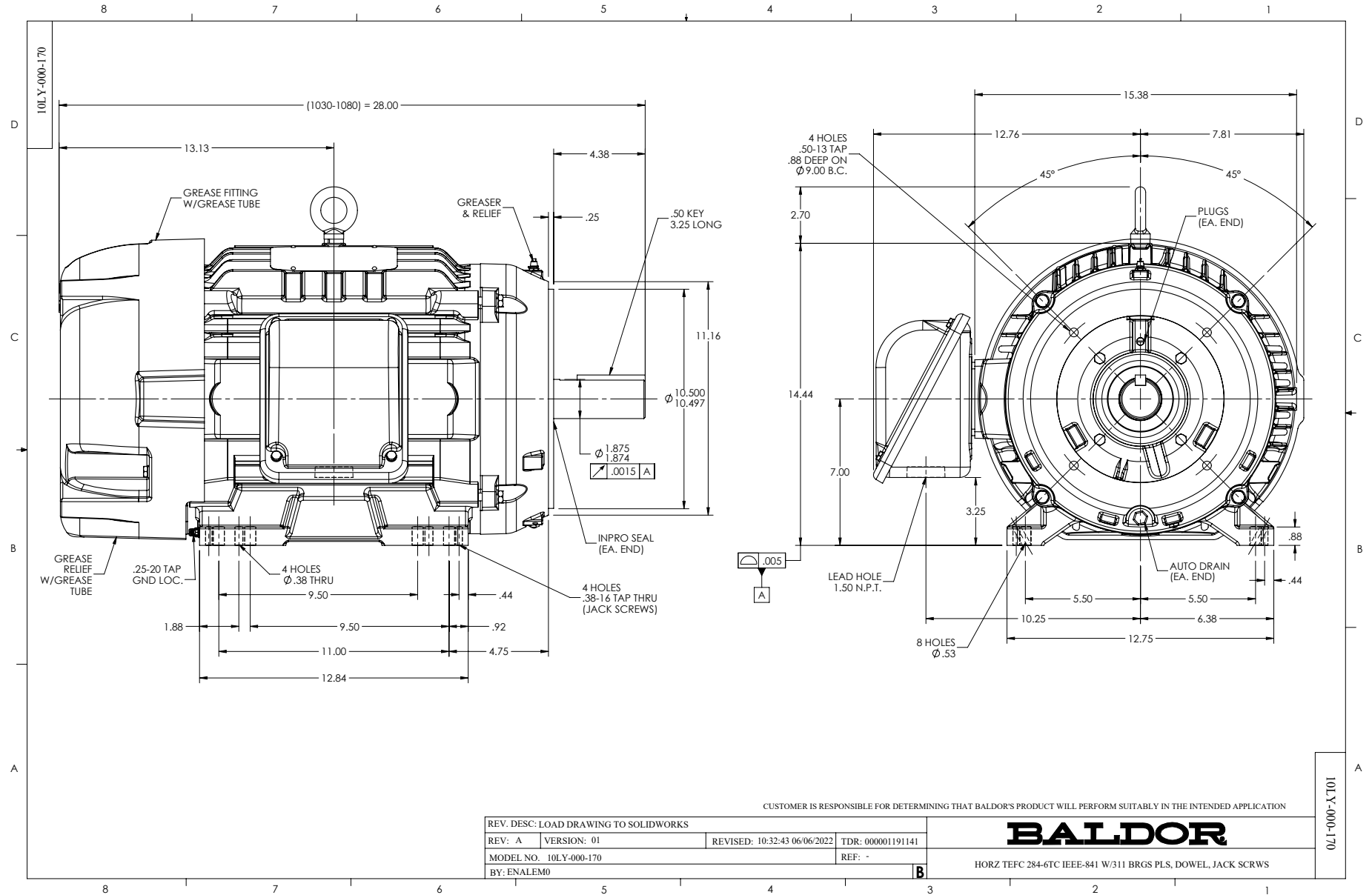

CD0006

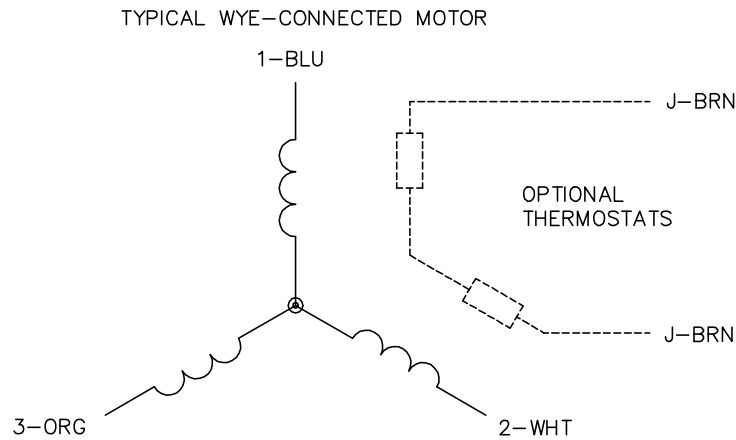

NOTES:

1. THREE LEAD MOTOR MAY BE EITHER WYE CONNECTED OR DELTA CONNECTED.
2. INTERCHANGE ANY TWO LINE LEADS TO REVERSE ROTATION.
3. OPTIONAL THERMOSTATS ARE PROVIDED WHEN SPECIFIED.
4. ACTUAL NUMBER OF INTERNAL PARALLEL CIRCUITS MAY VARY.
5. LEAD COLORS ARE OPTIONAL. LEADS MUST BE NUMBERED AS SHOWN.

CD0006

REV. DESC: ADD CLASS CONN00000007		
REV. LTR: E	VERSION: 01	TDR: 000001099922
FILE: \AAA\00005\141	REVISED: 10:24:49 02/19/2019	BY: ENBRIRO
MTL: -	© □	

BALDOR - RELIANCE®

3PH, SV, 3 LEADS, WYE OR DELTA CONNECTED

SH 1 of 1