

3.1.3 LWBC 40-63

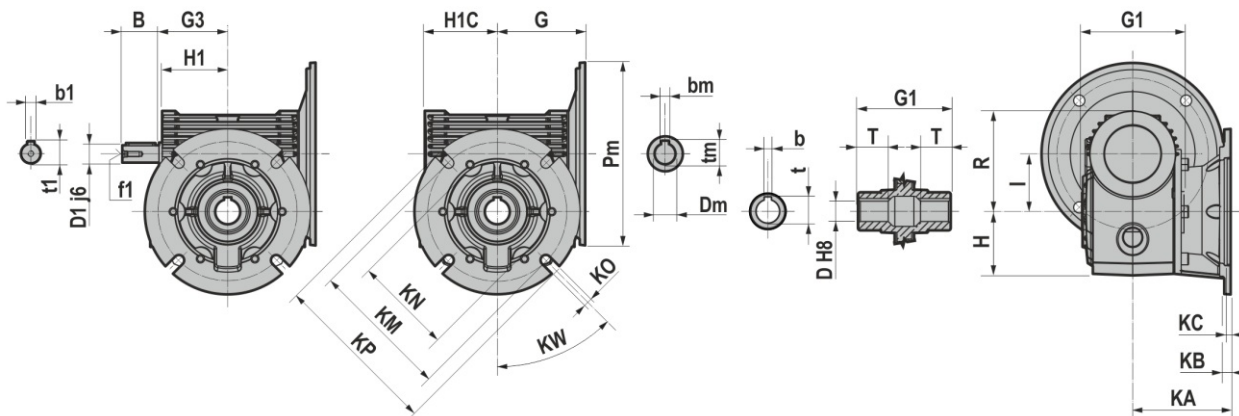

	40	50	63
B	23	30	40
D1j6	11	14	19
G	70	80	96
G1	78	92	112
G3	53	64	75
H	49	57	69,5
H1	52,5	62,5	71,5
H1C	54,5	64,5	79,5
I	40	50	63
KA	82	88	107
KB	10	10	12
KC	5	5	5
KO	9 (n°4)	9 (n°4)	11 (n°4)
KM	87	100	150
KN	60	70	115
KP	110	125	180
KW	45°	45°	45°
R	78	88	110
b1	4	5	6
t1	12,5	16	21,5
f1	-	M6	M6

	D H8	b	t	T
40	18	6	20,8	26
	19	6	21,8	26
50	25	8	28,3	30
	24	8	27,3	30
63	25	8	28,3	36
	28	8	31,3	36
	30	8	33,3	36

B5	Pm	Dm	bm	tm
056	120	9	3	10,4
063	140	11	4	12,8
071	160	14	5	16,3
080	200	19	6	21,8
090	200	24	8	27,3

B14	Pm	Dm	bm	tm
056	80	9	3	10,4
063	90	11	4	12,8
071	105	14	5	16,3
080	120	19	6	21,8
090	140	24	8	27,3