



Customer information packet

VECP83661T-4

3HP, 1755RPM, 3PH, 60HZ, 182TC, 0632M, TEFC, F1

ELECTRIC MOTOR WHOLESAL.COM

Class - CLI GP A,B,C,D

Division - Division II

Specifications

Enclosure	TEFC
Frame	182TC
Frame Material	Iron
Frequency	60.00 Hz
Motor Letter Type	Three Phase
Output @ Frequency	3.000 HP @ 60 HZ
Phase	3
Synchronous Speed @ Frequency	1800 RPM @ 60 HZ
Voltage @ Frequency	460.0 V @ 60 HZ
XP Class and Group	CLI GP A,B,C,D
XP Division	Division II
Agency Approvals	CSA CSA EEV UR
Ambient Temperature	40 °C
Auxillary Box	No Auxillary Box
Auxillary Box Lead Termination	None
Base Indicator	No Mounting
Bearing Grease Type	Polyrex EM (-20F +300F)
Blower	None
Constant Torque Speed Range	1.5
Current @ Voltage	4.100 A @ 460.0 V
Design Code	B
Drip Cover	No Drip Cover
Duty Rating	CONT
Efficiency @ 100% Load	89.5 %
Electrically Isolated Bearing	Not Electrically Isolated
Feedback Device	NO FEEDBACK
Front Face Code	Standard
Front Shaft Indicator	None
Heater Indicator	No Heater
High Voltage Full Load Amps	4.1 a

Part detail

Revision	X
Type	AC
Mech. spec.	06G105
Base	
Status	PRD/A
Elec. spec.	06WGX240
Layout	06LYG105
Eff. date	07-01-2022
CD Diagram	CD0006
Poles	04
Leads	3#16
Proprietary	False
Created date	10-05-2011

Insulation Class	F
Inverter Code	Inverter Duty
KVA Code	J
Lifting Lugs	Standard Lifting Lugs
Locked Bearing Indicator	Locked Bearing
Max Speed	2700 rpm
Motor Lead Exit	Ko Box
Motor Lead Quantity/Wire Size	3 @ 16 AWG
Motor Lead Termination	Flying Leads
Motor Standards	NEMA
Motor Type	0632M
Mounting Arrangement	F1
Number of Poles	4
Overall Length	16.69 IN
Power Factor	77
Product Family	Chem Process S/P 32-8 IEEE 841
Pulley End Bearing Type	Ball
Pulley Face Code	C-Face
Pulley Shaft Indicator	Standard
Rodent Screen	None
Service Factor	1.15
Shaft Diameter	1.125 IN
Shaft Extension Location	Pulley End
Shaft Ground Indicator	No Shaft Grounding
Shaft Rotation	Reversible
Shaft Slinger Indicator	Shaft Slinger
Speed	1755 rpm
Speed Code	Single Speed
Starting Method	Direct on line
Thermal Device - Bearing	None
Thermal Device - Winding	None
Vibration Sensor Indicator	No Vibration Sensor
Winding Thermal 1	None
Winding Thermal 2	None

XP Temp Code

T3C

Nameplate

NP4328E									
CAT.NO.	VECP83661T-4								
SPEC.	06G105X240G1								
HP	3 TE	IP	56						
VOLTS	460								
AMPS	4.1								
R.P.M.	1755								
FRAME	182TC	HZ	60	PH	3				
SER.F.	1.15	CODE	J	DES.	B	CLASS	F		
RATING	40C AMB-CONT								
SN									
DE	6206	ODE	6206						
NEMA NOM. EFF.	89.5	P.F.	77						
GUAR. MIN. EFF.	87.5	CC	010A						
T. CODE	T3C	TEMP=	160						

NP3186E

SPEC.	06G105X240G1		
ABMA DE BRG	30BC02XP30X		
ABMA ODE BRG	30BC02X30X		
GREASE	POLYREX EM		
MOTOR WEIGHT	117	ROTOR BARS	28
		STATOR BARS	36
MAX. R.P.M.	2700	MAX. KVAR	.94
INV.TYPE	PWM		
T=	160		
CHP	60	TO	90
CT	1.5	TO	60
VT	0-	TO	60
HTR-VOLTS	N/A	HTR-AMPS	N/A
HTR-WATTS		MAX. SPACE HEATER TEMP.	N/A

Parts list

Part number	Description	Quantity
SA231980	SA 06G105X240G1	1.000 ea
RA218990	RA 06G105X240G1	1.000 ea
36FN3000C01SP	EXFN, PLASTIC, 5.25 OD, .912 ID	1.000 ea
HW3201A05	3/8-16 EYEBOLT	1.000 ea
06CB1001A01G	CONDUIT BOX, MACH GRAY	1.000 ea
RM1016	LEAD SEPARATOR GASKET - 305/306 C.P.MOTO	1.000 ea
51XF2520A16	SCREW,HEX SER SLT HD,ZN 1/4-20X1.00LG TD	2.000 ea
11XW1032G06	10-32 X .38, TAPTITE II, HEX WSHR SLTD U	1.000 ea
HW3001B01	BRASS CUP WASHER, FOR #10 SCREW	1.000 ea
WD1000B16	T&B CX70TN OR L70P TERMINAL LUG	2.000 ea
10XN2520G06	1/4 20X3/8 HX HD CAP, GREEN	2.000 ea
06PE1132A02G	FREP ASSEMBLY FOR ROUTING PURPOSES	1.000 ea
HW4601B24	INPRO SEAL, 206 BRG, MINI66	1.000 ea
HW4500A32	FIT./EXT 1698-B (ALEMITE)GREASE FITTING	1.000 ea
HA4051A00	PLASTIC CAP FOR GREASE FITTING	1.000 ea
51XN1032A20	10-32 X 1 1/4 HX WS SL SR	4.000 ea
HW4500A17	317400 ALEMITE GREASE RELIEF	1.000 ea
HA4010A01	T-DRAIN PLUG,416 S.S.,W/ 1/4-28 THD & .0	1.000 ea
HW5100A06	W2420-025 WVY WSHR (WB)	1.000 ea
36EP1300A88G	PUEP 206 LK'D BRG,GRSR & RLF,INPRO SEAL	1.000 ea
HW4601B26	INPRO SEAL, 206 BRG, MINI66	1.000 ea
HW4500A01	1641B(ALEMITE)400 UNIV, GREASE FITT	1.000 ea
HA4051A00	PLASTIC CAP FOR GREASE FITTING	1.000 ea
HW4500A17	317400 ALEMITE GREASE RELIEF	1.000 ea
HA4002A03	#304 S.S. DRAIN FITTING, .125 NPT (.44 H	1.000 ea
10XN2520A24	1/4-20X 1 1/2 HEX HD X	4.000 ea
HA3101A53	THRUBOLT 1/4-20 X 10.50	4.000 ea
XY2520A12	1/4-20 HEX NUT, DIRECTIONAL SERRATIONS	4.000 ea
51XB1214A16	12-14X1.00 HXWSSLD SERTYB	1.000 ea
06FH1004A01G	FAN HOUSING MACH, W/GRAY EPOXY	1.000 ea
10XN2520A24	1/4-20X 1 1/2 HEX HD X	3.000 ea

WD4100A02	DP-1000 HEYCO PLUG OR 62MP1000 MICRO PL	1.000 ea
06CB1503A01G	LIPPED CONDUIT BOX LID, MACH GRAY EPOXY	1.000 ea
06GS1009	GASKET, KOBX LID, 1/8" THICK BLACK NEOPR	1.000 ea
10XN2520A12	1/4-20 X 3/4 HEX HEAD CAP	2.000 ea
HW1001A25	LOCKWASHER 1/4, ZINC PLT .493 OD, .255 I	2.000 ea
MJ5001A02	732 CL SEALANT 3 OZ DIXIE BEARING 289100	0.010 ea
HW2501E16	KEY, 1/4 SQ X 1.750	1.000 ea
HA7000A02	KEY RETAINER RING, 1 1/8 DIA, 1 3/8 DIA	1.000 ea
MJ5001A27	32220KN GRAY SEALER *MIN BUY 4 QTS=1GAL	0.001 qt
MJ1000A73	INPRO P-80 ASSEMBLY LUB./ 1 QT. CONTAIN	0.001 qt
85XU0407S04	4X1/4 U DRIVE PIN STAINLESS	4.000 ea
LB1115N	LABEL,LIFTING DEVICE (ON ROLLS)	1.000 ea
LT0019A00	MOTOR NO-LOAD PERFORMANCE DATA SHEET	1.000 ea
WD1000D21	TRM,T&B #B71M,RING,18-14,.25,NON-INSL	3.000 ea
MJ1000A02	GREASE, POLYREX EM EXXON	0.050 lb
MG1025N19	WILKOFAS, 778.50, RELIANCE BLUE-GREEN 8	0.028 ga
LB1119N	WARNING LABEL	1.000 ea
LB1449	DIV-2/NEC WARNING LABEL	1.000 ea
LC0006	CONNECTION LABEL	1.000 ea
NP4328E	SS IEEE841-2021 DIV-2 UL CSA-C US EEV	1.000 ea
NP3186E	SS IEEE841 INV AUX DATA INFORMATION	1.000 ea
36PA1001	PKG GRP, PRINT PK1017A06	1.000 ea
MN416A01	TAG-INSTAL-MAINT no wire (2200bx) 4/22	1.000 ea

AC Induction Motor Performance Data

Record # 92246

Typical performance - not guaranteed values

Winding: 06WGX240-R041		Type: 0632M		Enclosure: TEFC	
Nameplate Data			460 V, 60 Hz: Single Voltage Motor		
Rated Output (HP)	3	Full Load Torque	9.06 LB-FT		
Volts	460	Start Configuration	direct on line		
Full Load Amps	4.1	Breakdown Torque	33.1 LB-FT		
R.P.M.	1755	Pull-up Torque	18.2 LB-FT		
Hz	60	Locked-rotor Torque	20.4 LB-FT		
NEMA Design Code	B	Starting Current	29.8 A		
Service Factor (S.F.)	1.15	No-load Current	2.14 A		
NEMA Nom. Eff.	89.5	Line-line Res. @ 25°C	3.93 Ω		
Rating - Duty	40C	Temp. Rise @ Rated Load	35°C		
S.F. Amps	AMB-CONT	Temp. Rise @ S.F. Load	42°C		
		Locked-rotor Power Factor	41.4		
		Rotor inertia	0.298 lb-ft ²		

Load Characteristics 460 V, 60 Hz, 3 HP

% of Rated Load	25	50	75	100	125	150	S.F.
Power Factor	38	58	70	77	81	83	79
Efficiency	83.2	88.3	89.8	89.5	89.1	87.7	89.3
Speed	1790	1779	1769	1757	1744	1730	1749
Line amperes	2.34	2.79	3.39	4.1	4.91	5.86	4.59

ABB Motors and Mechanical Inc.

WINDING # 06WGX240

3 HP 3 PH 60 HZ 1755 RPM 460 V 0632M

Typical performance - not guaranteed values.

TORQUES (LB-FT): PO=33.1 PU=18.2 LR=20.4 LRA=29.8

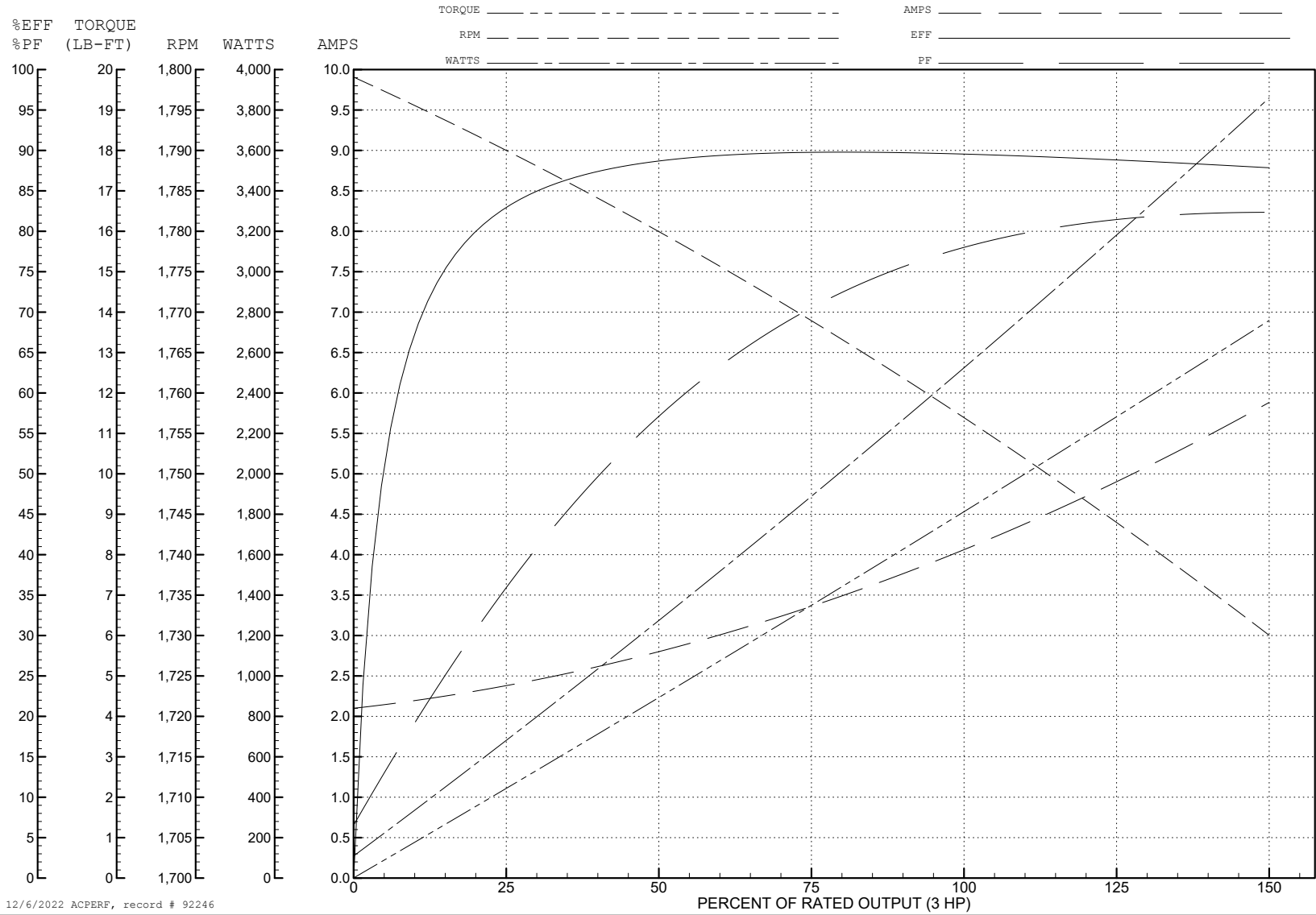

12/6/2022 ACPERF, record # 92246

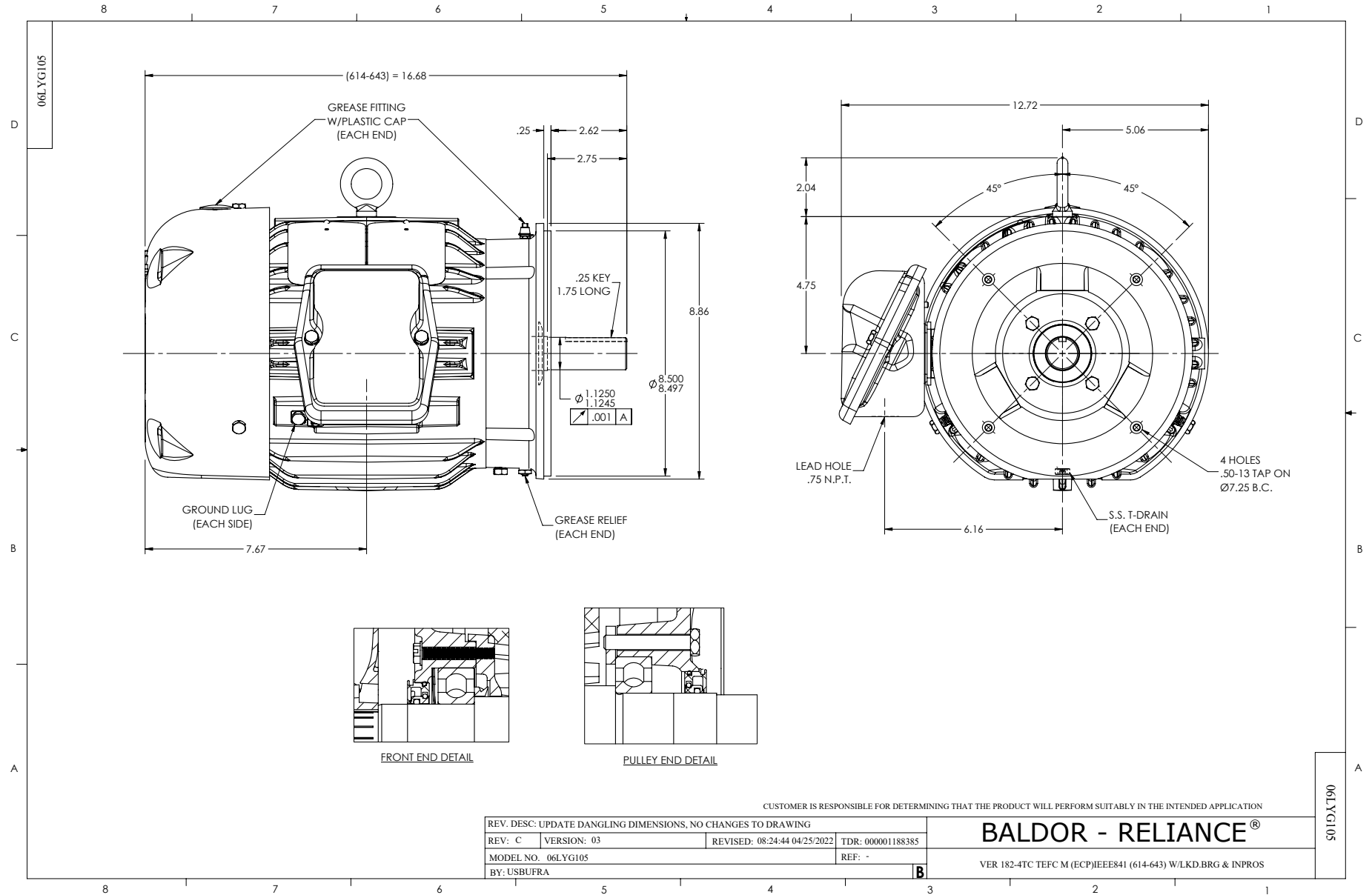

CD0006

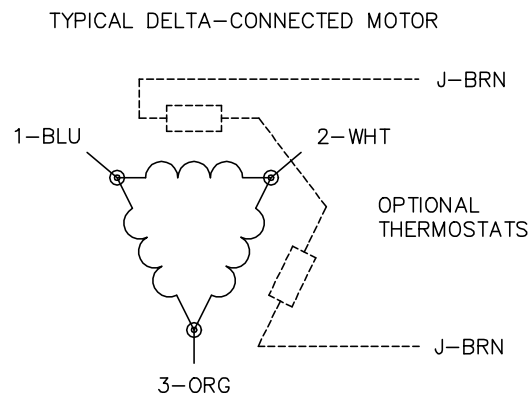
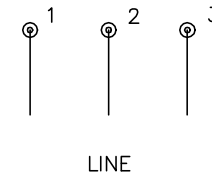
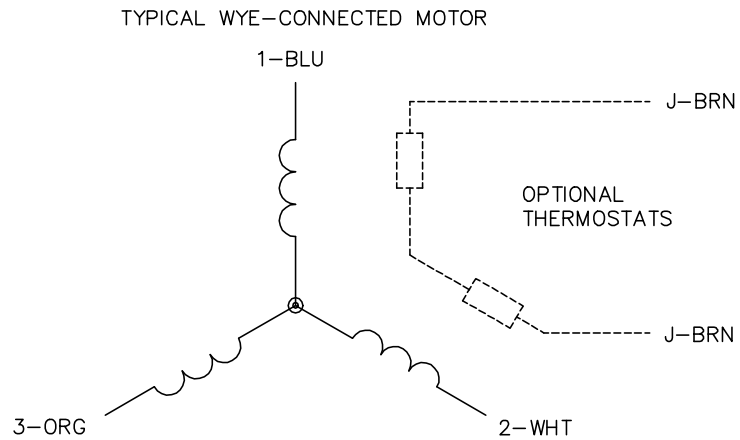

NOTES:

1. THREE LEAD MOTOR MAY BE EITHER WYE CONNECTED OR DELTA CONNECTED.
2. INTERCHANGE ANY TWO LINE LEADS TO REVERSE ROTATION.
3. OPTIONAL THERMOSTATS ARE PROVIDED WHEN SPECIFIED.
4. ACTUAL NUMBER OF INTERNAL PARALLEL CIRCUITS MAY VARY.
5. LEAD COLORS ARE OPTIONAL. LEADS MUST BE NUMBERED AS SHOWN.

CD0006

REV. DESC: ADD CLASS CONN00000007		
REV. LTR: E	VERSION: 01	TDR: 000001099922
FILE: \AAA\00005\141	REVISED: 10:24:49 02/19/2019	BY: ENBRIRO
MTL: -	© □	

BALDOR - RELIANCE®

3PH, SV, 3 LEADS, WYE OR DELTA CONNECTED

SH 1 of 1