



Customer information packet

EFM2394T

15HP, 3520RPM, 3PH, 60HZ, 254T, 0930M, TEFC, F2

ELECTRIC MOTOR WHOLESAL.COM

Class - None

Division - Not Applicable

Specifications

Enclosure	TEFC
Frame	254T
Frame Material	Iron
Frequency	60.00 Hz
Output @ Frequency	15.000 HP @ 60 HZ
Phase	3
Synchronous Speed @ Frequency	3600 RPM @ 60 HZ
Voltage @ Frequency	460.0 V @ 60 HZ 230.0 V @ 60 HZ
XP Class and Group	None
XP Division	Not Applicable
Agency Approvals	CSA CSA EEV UR
Ambient Temperature	40 °C
Auxillary Box	No Auxillary Box
Auxillary Box Lead Termination	None
Base Indicator	Rigid
Bearing Grease Type	Polyrex EM (-20F +300F)
Blower	None
Current @ Voltage	17.500 A @ 460.0 V 35.000 A @ 230.0 V 38.000 A @ 208.0 V
Design Code	B
Drip Cover	No Drip Cover
Duty Rating	CONT
Efficiency @ 100% Load	91.0 %
Electrically Isolated Bearing	Not Electrically Isolated
Feedback Device	NO FEEDBACK
Front Face Code	Standard
Front Shaft Indicator	None
Heater Indicator	No Heater

Part detail

Revision	U
Type	AC
Mech. spec.	09C106
Base	
Status	PRD/A
Elec. spec.	09WGZ602
Layout	09LYC106
Eff. date	10-27-2020
CD Diagram	CD0180
Poles	02
Leads	9#12
Proprietary	False
Created date	04-19-2013

High Voltage Full Load Amps	17.5 a
Insulation Class	F
Inverter Code	Inverter Ready
KVA Code	G
Lifting Lugs	Standard Lifting Lugs
Locked Bearing Indicator	No Locked Bearing
Motor Lead Exit	Ko Box
Motor Lead Quantity/Wire Size	9 @ 12 AWG
Motor Lead Termination	Flying Leads
Motor Standards	NEMA
Motor Type	0930M
Mounting Arrangement	F2
Number of Poles	2
Overall Length	23.28 IN
Power Factor	87
Product Family	General Purpose
Pulley End Bearing Type	Ball
Pulley Face Code	Standard
Pulley Shaft Indicator	Standard
Rodent Screen	None
Service Factor	1.15
Shaft Diameter	1.625 IN
Shaft Extension Location	Pulley End
Shaft Ground Indicator	No Shaft Grounding
Shaft Rotation	Reversible
Shaft Slinger Indicator	Shaft Slinger
Speed	3520 rpm
Speed Code	Single Speed
Starting Method	Direct on line
Thermal Device - Bearing	None
Thermal Device - Winding	None
Vibration Sensor Indicator	No Vibration Sensor
Winding Thermal 1	None
Winding Thermal 2	None

Nameplate

NP3441L									
CAT.NO.	EFM2394T								
SPEC.	09C106Z602G1								
HP	15								
VOLTS	230/460								
AMP	35/17.5								
RPM	3520								
FRAME	254T		HZ	60		PH	3		
SER.F.	1.15	CODE	G	DES	B	CL	F		
NEMA-NOM-EFF	91	PF	87						
RATING	40C AMB-CONT								
CC	010A		USABLE AT 208V				38		
DE	6309		ODE	6208					
ENCL	TEFC	SN							
VPWM INVERTER READY									
CT6-60H(10:1)VT3-60H(20:1									

Parts list

Part number	Description	Quantity
SA262090	SA 09C106Z602G1	1.000 ea
RA248823	RA 09C106Z602G1	1.000 ea
37FN3002C02	EXFN, PLASTIC, 6.00 OD, 1.503 ID	1.000 ea
HW1002A63	OASHER, 5/8 HI-COLLAR SPRLCKWASHER	1.000 ea
09CB3002SP	CB W/1.38 LEAD HOLE FOR 37, 39, 307 & 30	1.000 ea
09GS1000SP	GASKET-CONDUIT BOX, 1/16 THICK LEXIDE	1.000 ea
10XN2520K12	1/4-20 X.75 GRD 5	2.000 ea
HW1001A25	LOCKWASHER 1/4, ZINC PLT .493 OD, .255 I	2.000 ea
09EP1101A136	PU ENDPLATE, MACH	1.000 ea
WD1000B16	T&B CX70TN OR L70P TERMINAL LUG	1.000 ea
59XW2520G07	.25-20X.44,HEX SER WSHR,TAPTITE 2,GREEN	1.000 ea
09EP1100A208	ENDPLATE, MACH	1.000 ea
HW4600B44	V-RING SLINGER 1.500 X 1.810 X .28 VITON	1.000 ea
XY3816A12	3/8-16 FINISHED NUT	4.000 ea
HW1001A38	LOCKWASHER 3/8, ZINC PLT .688 OD, .382 I	4.000 ea
HW5100A08	W3118-035 WVY WSHR (WB)	1.000 ea
10XN2520K36	1/4-20 X 2.25" HX HD SCRWGRADE 5, ZINC P	4.000 ea
HW1001A25	LOCKWASHER 1/4, ZINC PLT .493 OD, .255 I	4.000 ea
HA3113A02	THRUBOLT 3/8-16 X 16.750	4.000 ea
HW1001A38	LOCKWASHER 3/8, ZINC PLT .688 OD, .382 I	4.000 ea
09FH4000SP	309 FH - BLACK PRIMER	1.000 ea
HA2081A05	SPACER TUBE, 309 FAN HSG, 2.00 LONG	4.000 ea
XY3816A12	3/8-16 FINISHED NUT	4.000 ea
HW1001A38	LOCKWASHER 3/8, ZINC PLT .688 OD, .382 I	4.000 ea
09CB3501SP	CONDUIT BOX LID FOR 09CB3001 & 09CB3002	1.000 ea
09GS1013SP	09 GS FOR 09CB3501 LID - LEXIDE	1.000 ea
51XW2520A12	.25-20 X .75, TAPTITE II, HEX WSHR SLTD	2.000 ea
HW2501G25	KEY, 3/8 SQ X 2.875	1.000 ea
LB1115N	LABEL,LIFTING DEVICE (ON ROLLS)	1.000 ea
MN416A01	TAG-INSTAL-MAINT no wire (1200/bx) 3/19	1.000 ea
LD7020D09	LEAD SET, 12AWG, 9 LEAD, 20" LONG LEADS	1.000 ea

HA4051A00	PLASTIC CAP FOR GREASE FITTING	1.000 ea
HW4500A05	1669B ALEM/UNIV860 GR FTG X	1.000 ea
HW4500A17	317400 ALEMITE GREASE RELIEF	1.000 ea
HA4066A01	PUSH IN T-DRAIN FITTING (BLACK)	1.000 ea
HW4500A17	317400 ALEMITE GREASE RELIEF	1.000 ea
HA4066A01	PUSH IN T-DRAIN FITTING (BLACK)	1.000 ea
HW4500A03	GREASE FITTING, .125 NPT 1610(ALEMITE) 8	1.000 ea
MJ1000A02	GREASE, MOBIL POLYREX EM - 124047	0.080 lb
HA4051A00	PLASTIC CAP FOR GREASE FITTING	1.000 ea
HW2500A25	WOODRUFF KEY USA #1008 #BLOW CARBON STEE	1.000 ea
51XB1214A20	12-14X1.25 HXWSSLD SERTYB	1.000 ea
MG1000Y03	MUNSELL 2.53Y 6.70/ 4.60, GLOSS 20,	0.050 ga
85XU0407S04	4X1/4 U DRIVE PIN STAINLESS	2.000 ea
LB1119N	WARNING LABEL	1.000 ea
LC0181	CONNECTION LABEL	1.000 ea
NP3441L	ALUM SUPER-E VPWM INVERTER READY UL	1.000 ea
09PA1000	PACKAGING GROUP COMBINED PRINT	1.000 ea
PE-0000003	ZRTG PE ASSEMBLY	1.000 ea
FE-0000013	ZRTG FE ASSEMBLY	1.000 ea

AC Induction Motor Performance Data

Record # 31412

Typical performance - not guaranteed values

Winding: 09WGZ602-R001		Type: 0930M	Enclosure: TEFC	
Nameplate Data			460 V, 60 Hz: High Voltage Connection	
Rated Output (HP)	15	Full Load Torque	22.1 LB-FT	
Volts	230/460	Start Configuration	direct on line	
Full Load Amps	35/17.5	Breakdown Torque	105 LB-FT	
R.P.M.	3525	Pull-up Torque	26.2 LB-FT	
Hz	60 Phase	3	Locked-rotor Torque	36.3 LB-FT
NEMA Design Code	B KVA Code	G	Starting Current	110 A
Service Factor (S.F.)	1.15	No-load Current	5.58 A	
NEMA Nom. Eff.	91 Power Factor	87	Line-line Res. @ 25°C	0.68654 Ω
Rating - Duty	40C AMB-CONT	Temp. Rise @ Rated Load	63°C	
S.F. Amps		Temp. Rise @ S.F. Load	78°C	
		Locked-rotor Power Factor	30	
		Rotor inertia	0.766 LB-FT ²	

Load Characteristics 460 V, 60 Hz, 15 HP

% of Rated Load	25	50	75	100	125	150	S.F.
Power Factor	55	77	85	87	89	89	88
Efficiency	86.4	91	91.6	91	90	88.6	90.4
Speed	3582.7	3563.6	3542.7	3520.9	3495.8	3468.3	3506
Line amperes	6.93	9.78	13.5	17.5	21.6	26.4	20

ABB Motors and Mechanical Inc.

WINDING # 09WGZ602

Typical performance - not guaranteed values.

15 HP 3 PH 60 HZ 3525 RPM 460 V 0930M

TORQUES (LB-FT): PO=105 PU=26.2 LR=36.3 LRA=110

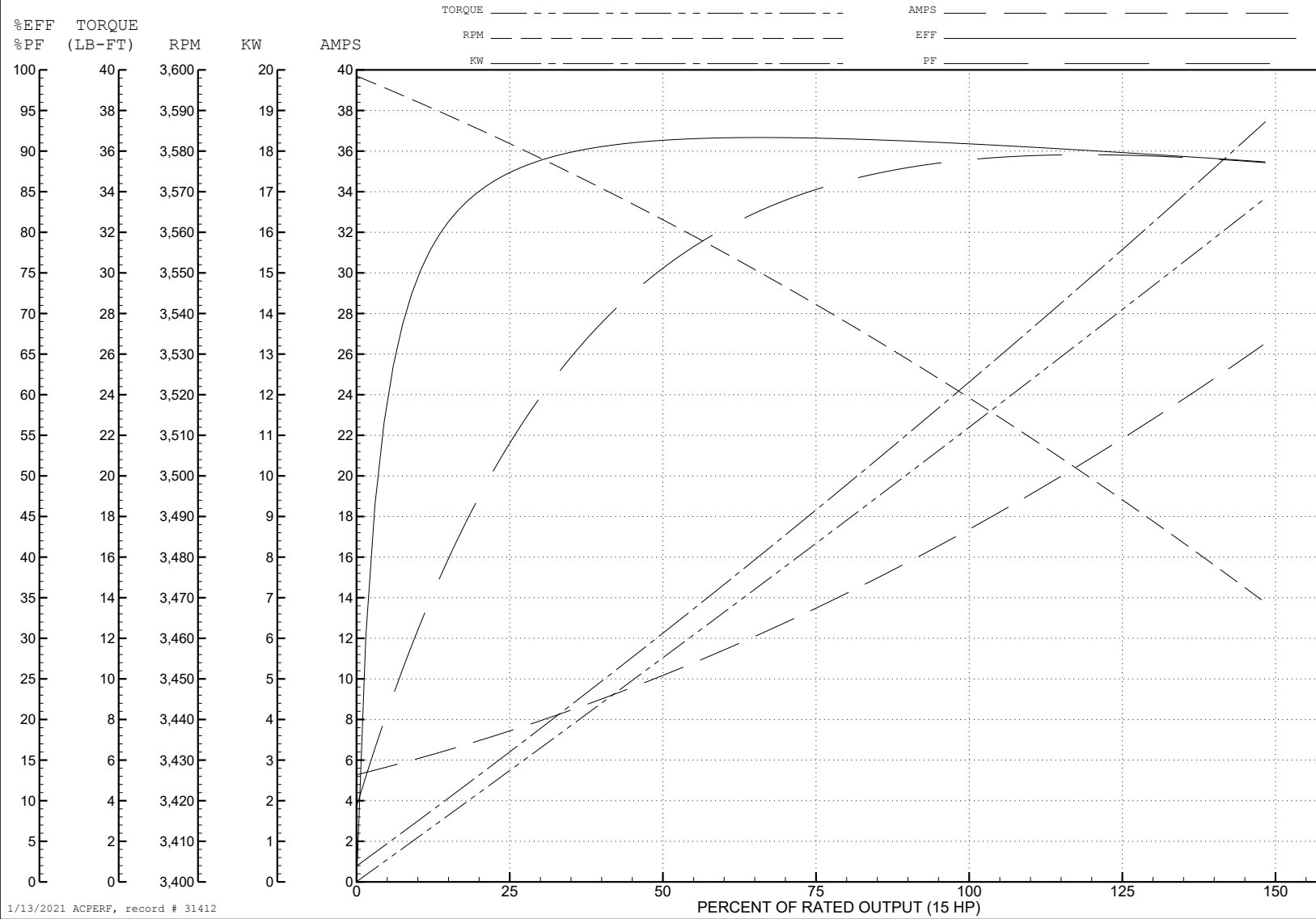

1/13/2021 ACPERF, record # 31412

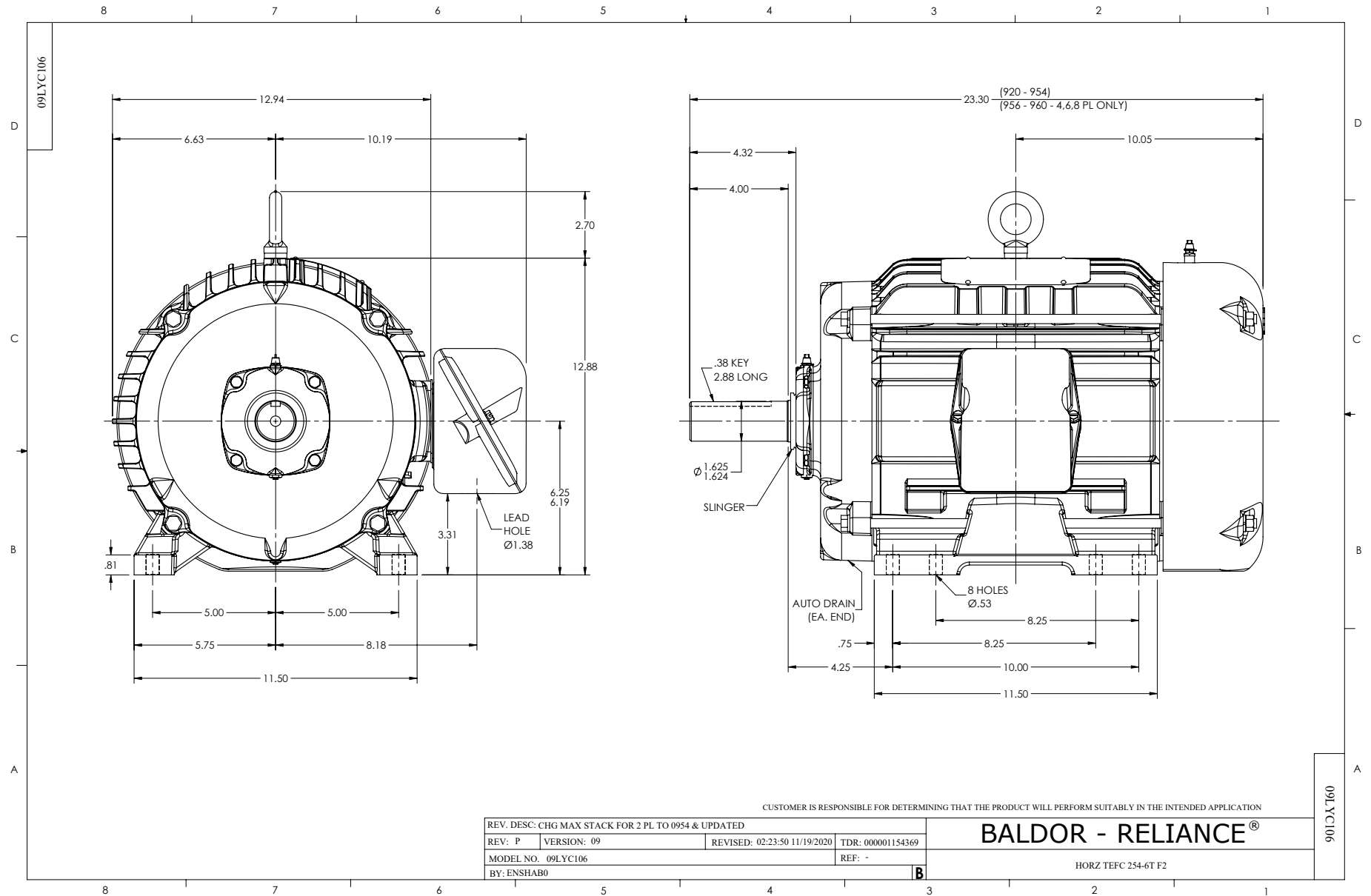

CD0180

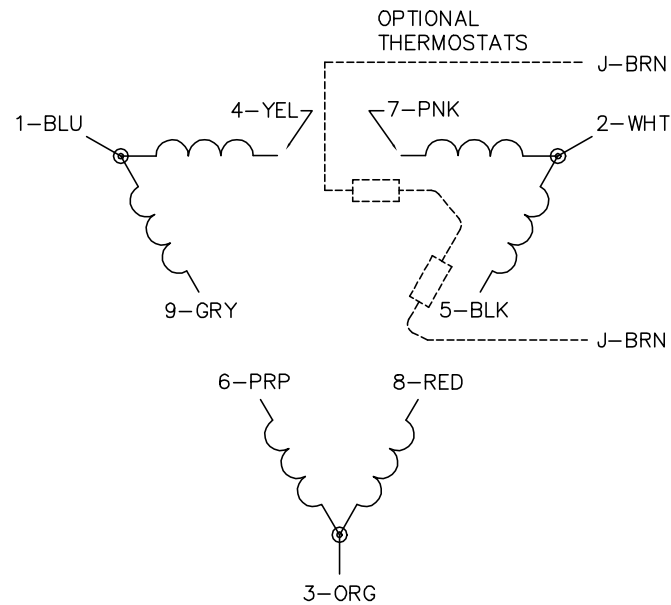

LOW VOLTAGE
(2D)

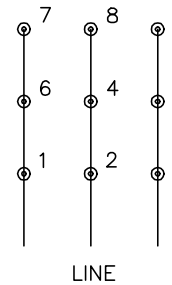

HIGH VOLTAGE
(1D)

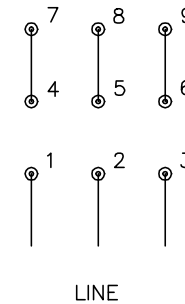

NOTES:

1. INTERCHANGE ANY TWO LINE LEADS TO REVERSE ROTATION.
2. OPTIONAL THERMOSTATS ARE PROVIDED WHEN SPECIFIED.
3. ACTUAL NUMBER OF INTERNAL PARALLEL CIRCUITS MAY BE A MULTIPLE OF THOSE SHOWN ABOVE.
4. LEAD COLORS ARE OPTIONAL. LEADS MUST ALWAYS BE NUMBERED AS SHOWN.

CD0180

REV. DESC: ADD CLASS CONN00000007		
REV. LTR: D	VERSION: 01	TDR: 000001099922
FILE: \AAA\00005\148	REVISED: 10: 25: 29 02/19/2019	BY: ENBRIRO
MTL: -	© □	

BALDOR - RELIANCE®

3PH, DV, 9 LEADS, DELTA CONNECTION

SH 1 of 1