



Customer information packet

CECP83665T-5

5HP, 1750RPM, 3PH, 60HZ, 184TC, 0641M, TEFC, F1

Class - CLI GP A,B,C,D

Division - Division II

Specifications

Enclosure	TEFC
Frame	184TC
Frame Material	Iron
Frequency	60.00 Hz
Motor Letter Type	Three Phase
Output @ Frequency	5.000 HP @ 60 HZ
Phase	3
Synchronous Speed @ Frequency	1800 RPM @ 60 HZ
Voltage @ Frequency	575.0 V @ 60 HZ
XP Class and Group	CLI GP A,B,C,D
XP Division	Division II
Agency Approvals	UR CSA CSA EEV
Ambient Temperature	40 °C
Auxillary Box	No Auxillary Box
Auxillary Box Lead Termination	None
Base Indicator	Rigid
Bearing Grease Type	Polyrex EM (-20F +300F)
Blower	None
Constant Torque Speed Range	1.7
Current @ Voltage	5.300 A @ 575.0 V
Design Code	B
Drip Cover	No Drip Cover
Duty Rating	CONT
Efficiency @ 100% Load	89.5 %
Electrically Isolated Bearing	Not Electrically Isolated
Feedback Device	NO FEEDBACK
Front Face Code	Standard
Front Shaft Indicator	None
Heater Indicator	No Heater
High Voltage Full Load Amps	5.3 a

Part detail

Revision	AD
Type	AC
Mech. spec.	06H770
Base	
Status	PRD/A
Elec. spec.	06WGX200
Layout	06LYH770
Eff. date	09-12-2022
CD Diagram	CD0006
Poles	04
Leads	3#16
Proprietary	False
Created date	04-05-2012

Insulation Class	F
Inverter Code	Inverter Duty
KVA Code	J
Lifting Lugs	Standard Lifting Lugs
Locked Bearing Indicator	Locked Bearing
Max Speed	2700 rpm
Motor Lead Exit	Ko Box
Motor Lead Quantity/Wire Size	3 @ 16 AWG
Motor Lead Termination	Flying Leads
Motor Standards	NEMA
Motor Type	0642M
Mounting Arrangement	F1
Number of Poles	4
Overall Length	16.69 IN
Power Factor	79
Product Family	Chem Process S/P 32-8 IEEE 841
Pulley End Bearing Type	Ball
Pulley Face Code	C-Face
Pulley Shaft Indicator	Standard
Rodent Screen	None
RoHS Status	ROHS COMPLIANT
Service Factor	1.15
Shaft Diameter	1.125 IN
Shaft Extension Location	Pulley End
Shaft Ground Indicator	No Shaft Grounding
Shaft Rotation	Reversible
Shaft Slinger Indicator	Shaft Slinger
Speed	1750 rpm
Speed Code	Single Speed
Starting Method	Direct on line
Thermal Device - Bearing	None
Thermal Device - Winding	None
Vibration Sensor Indicator	No Vibration Sensor
Winding Thermal 1	None

Winding Thermal 2

None

XP Temp Code

T3C

Nameplate

NP4328E									
CAT.NO.	CECP83665T-5								
SPEC.	06H770X200G1								
HP	5 TE		IP	56					
VOLTS	575								
AMPS	5.3								
R.P.M.	1750								
FRAME	184TC		HZ	60		PH	3		
SER.F.	1.15	CODE	J	DES.	B	CLASS	F		
RATING	40C AMB-CONT								
SN									
DE	6206		ODE	6206					
NEMA NOM. EFF.	89.5		P.F.	79					
GUAR. MIN. EFF.	87.5	CC	010A						
T. CODE	T3C	TEMP=	160						

NP3186E

SPEC.	06H770X200G1		
ABMA DE BRG	30BC02XP30X		
ABMA ODE BRG	30BC02X30X		
GREASE	POLYREX EM		
MOTOR WEIGHT	131	ROTOR BARS	28
		STATOR BARS	36
MAX. R.P.M.	2700	MAX. KVAR	1.22
INV.TYPE	PWM		
T=	160		
CHP	60	TO	90
CT	1.7	TO	60
VT	0-	TO	60
HTR-VOLTS	N/A	HTR-AMPS	N/A
HTR-WATTS		MAX. SPACE HEATER TEMP.	N/A

AC Induction Motor Performance Data

Record # 92586

Typical performance - not guaranteed values

Winding: 06WGX200-R025		Type: 0642M		Enclosure: TEFC	
Nameplate Data			575 V, 60 Hz: Single Voltage Motor		
Rated Output (HP)	5	Full Load Torque	15 LB-FT		
Volts	575	Start Configuration	direct on line		
Full Load Amps	5.3	Breakdown Torque	52.3 LB-FT		
R.P.M.	1750	Pull-up Torque	21.6 LB-FT		
Hz	60 Phase	Locked-rotor Torque	30.7 LB-FT		
NEMA Design Code	B KVA Code	Starting Current	36.8 A		
Service Factor (S.F.)	1.15	No-load Current	2.34 A		
NEMA Nom. Eff.	89.5 Power Factor	Line-line Res. @ 25°C	4.27 Ω		
Rating - Duty	40C AMB-CONT	Temp. Rise @ Rated Load	54°C		
S.F. Amps		Temp. Rise @ S.F. Load	67°C		
		Locked-rotor Power Factor	40.6		
		Rotor inertia	0.391 lb-ft ²		

Load Characteristics 575 V, 60 Hz, 5 HP

% of Rated Load	25	50	75	100	125	150	S.F.
Power Factor	42	64	76	79	84	85	81
Efficiency	85.2	89.8	90.1	89.5	88.2	86.4	89
Speed	1788	1777	1764	1751	1736	1719	1738
Line amperes	2.61	3.26	4.13	5.3	6.31	7.59	5.97

ABB Motors and Mechanical Inc.

WINDING # 06WGX200

5 HP 3 PH 60 HZ 1750 RPM 575 V 0642M

Typical performance - not guaranteed values.

TORQUES (LB-FT): PO=52.3 PU=21.6 LR=30.7 LRA=36.8

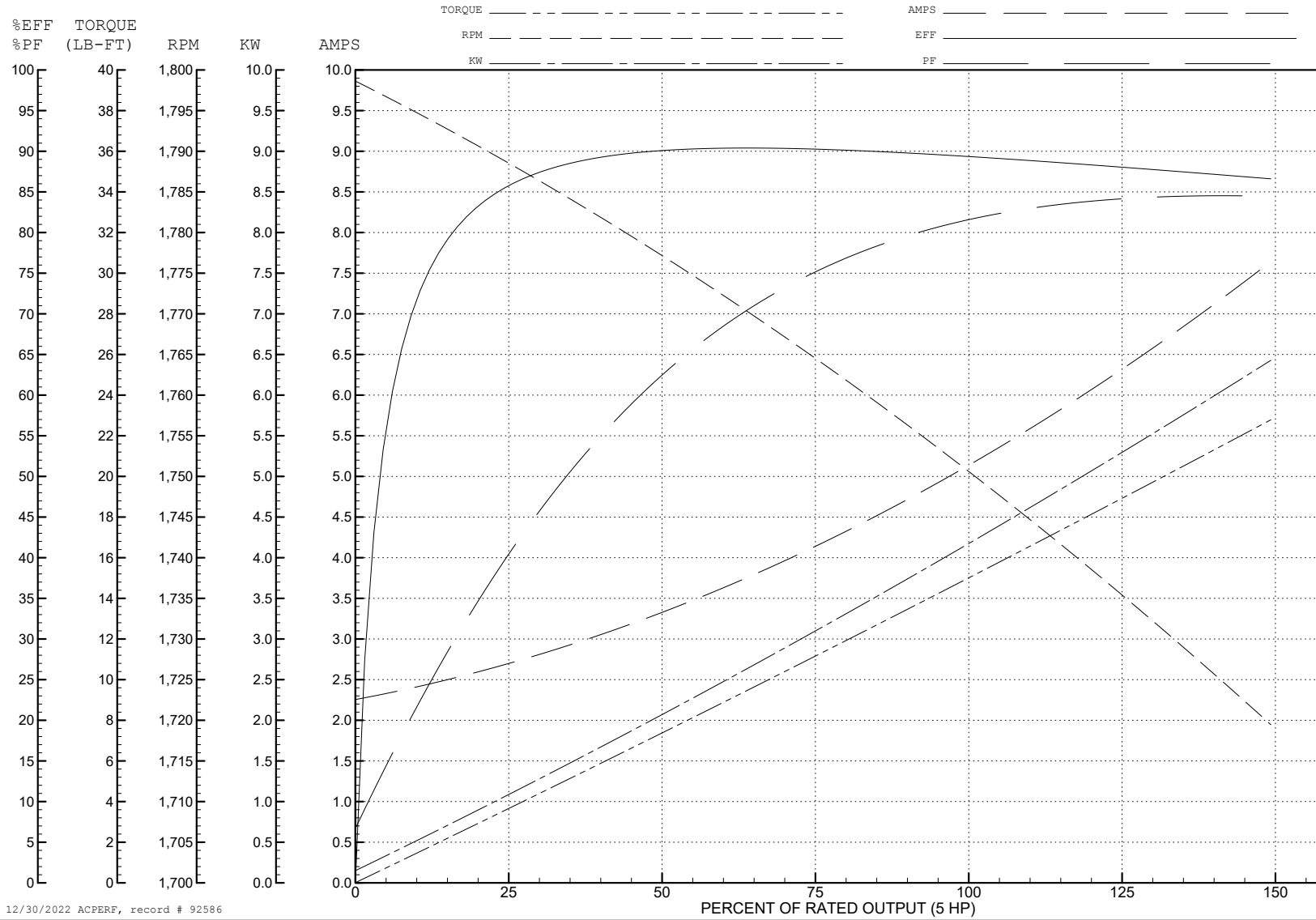

12/30/2022 ACPERF, record # 92586

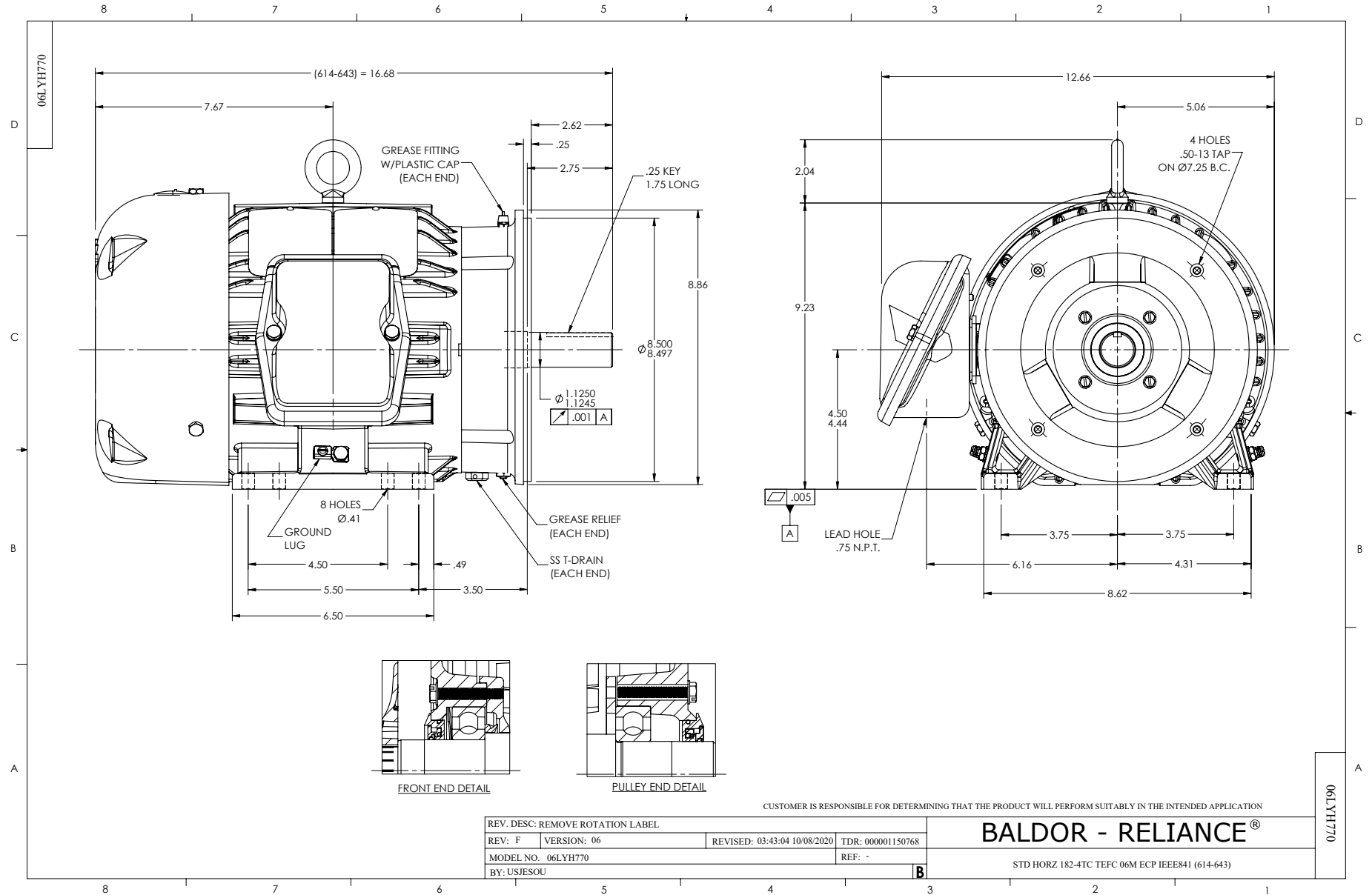

CD0006

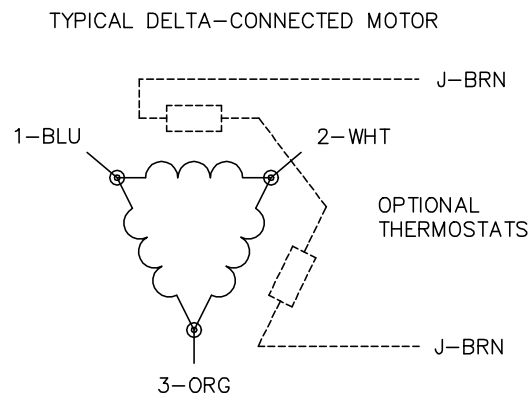
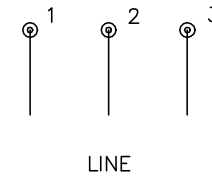
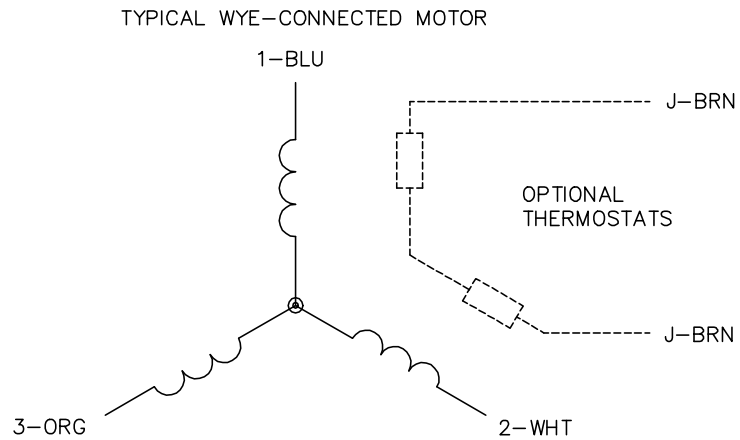

NOTES:

1. THREE LEAD MOTOR MAY BE EITHER WYE CONNECTED OR DELTA CONNECTED.
2. INTERCHANGE ANY TWO LINE LEADS TO REVERSE ROTATION.
3. OPTIONAL THERMOSTATS ARE PROVIDED WHEN SPECIFIED.
4. ACTUAL NUMBER OF INTERNAL PARALLEL CIRCUITS MAY VARY.
5. LEAD COLORS ARE OPTIONAL. LEADS MUST BE NUMBERED AS SHOWN.

CD0006

REV. DESC: ADD CLASS CONN00000007		
REV. LTR: E	VERSION: 01	TDR: 000001099922
FILE: \AAA\00005\141	REVISED: 10:24:49 02/19/2019	BY: ENBRIRO
MTL: -	© □	

BALDOR - RELIANCE®

3PH, SV, 3 LEADS, WYE OR DELTA CONNECTED

SH 1 of 1