

**BALDOR® • RELIANCE** 

**Product Information Packet**

**EM3546T-8**

**1HP,1760RPM,3PH,60HZ,143T,3520M,TEFC,F1**

Part Detail							
Revision:	Q	Status:	PRD/A	Change #:		Proprietary:	No
Type:	AC	Elec. Spec:	35WGM848	CD Diagram:	CD0006	Mfg Plant:	
Mech. Spec:	35AA001	Layout:	35LYAA001	Poles:	04	Created Date:	08-02-2010
Base:	RG	Eff. Date:	03-13-2018	Leads:	3#18		

Specs			
Catalog Number:	EM3546T-8	Inverter Code:	Inverter Ready
Enclosure:	TEFC	IP Rating:	NONE
Frame:	143T	KVA Code:	L
Frame Material:	Steel	Lifting Lugs:	No Lifting Lugs
Motor Letter Type:	Three Phase	Locked Bearing Indicator:	No Locked Bearing
Output @ Frequency:	1.000 HP @ 60 HZ	Motor Lead Quantity/Wire Size:	3 @ 18 AWG
Synchronous Speed @ Frequency:	1800 RPM @ 60 HZ	Motor Lead Exit:	Ko Box
Voltage @ Frequency:	200.0 V @ 60 HZ	Motor Lead Termination:	Flying Leads
XP Class and Group:	None	Motor Type:	3520M
XP Division:	Not Applicable	Mounting Arrangement:	F1
Agency Approvals:	UR	Power Factor:	71
	CSA EEV	Product Family:	General Purpose
	CSA	Pulley End Bearing Type:	Ball
Auxillary Box:	No Auxillary Box	Pulley Face Code:	Standard
Auxillary Box Lead Termination:	None	Pulley Shaft Indicator:	Standard
Base Indicator:	Rigid	Rodent Screen:	None
Bearing Grease Type:	Polyrex EM (-20F +300F)	RoHS Status:	ROHS COMPLIANT
Blower:	None	Shaft Extension Location:	Pulley End

<b>Current @ Voltage:</b>	3.500 A @ 200.0 V	<b>Shaft Ground Indicator:</b>	No Shaft Grounding
<b>Design Code:</b>	B	<b>Shaft Rotation:</b>	Reversible
<b>Drip Cover:</b>	No Drip Cover	<b>Shaft Slinger Indicator:</b>	No Slinger
<b>Duty Rating:</b>	CONT	<b>Speed Code:</b>	Single Speed
<b>Electrically Isolated Bearing:</b>	Not Electrically Isolated	<b>Motor Standards:</b>	NEMA
<b>Feedback Device:</b>	NO FEEDBACK	<b>Starting Method:</b>	Direct on line
<b>Front Face Code:</b>	Standard	<b>Thermal Device - Bearing:</b>	None
<b>Front Shaft Indicator:</b>	None	<b>Thermal Device - Winding:</b>	None
<b>Heater Indicator:</b>	No Heater	<b>Vibration Sensor Indicator:</b>	No Vibration Sensor
<b>Insulation Class:</b>	F	<b>Winding Thermal 1:</b>	None
		<b>Winding Thermal 2:</b>	None

<b>Nameplate NP3441L</b>										
<b>CAT.NO.</b>	EM3546T-8									
<b>SPEC.</b>	35AA001M848G1									
<b>HP</b>	1									
<b>VOLTS</b>	200									
<b>AMP</b>	3.5									
<b>RPM</b>	1760									
<b>FRAME</b>	143T			<b>HZ</b>	60				<b>PH</b>	3
<b>SER.F.</b>	1.15		<b>CODE</b>	L		<b>DES</b>	B		<b>CL</b>	F
<b>NEMA-NOM-EFF</b>	85.5		<b>PF</b>	71						
<b>RATING</b>	40C AMB-CONT									
<b>CC</b>	010A					<b>USABLE AT 208V</b>				
<b>DE</b>	6205			<b>ODE</b>	6203					
<b>ENCL</b>	TEFC		<b>SN</b>							
<b>VPWM INVERTER READY</b>										
CT6-60H(10:1)VT3-60H(20:1)										

**AC Induction Motor Performance Data**

Record # 32066

Typical performance - not guaranteed values

<b>Winding: 35WGM848-R001</b>		<b>Type: 3520M</b>		<b>Enclosure: TEFC</b>	
<b>Nameplate Data</b>			<b>200 V, 60 Hz: Single Voltage Motor</b>		
<b>Rated Output (HP)</b>	1	<b>Full Load Torque</b>	2.99 LB-FT		
<b>Volts</b>	200	<b>Start Configuration</b>	direct on line		
<b>Full Load Amps</b>	3.5	<b>Breakdown Torque</b>	13.4 LB-FT		
<b>R.P.M.</b>	1760	<b>Pull-up Torque</b>	8.19 LB-FT		
<b>Hz</b>	60	<b>Phase</b>	3	<b>Locked-rotor Torque</b>	8.46 LB-FT
<b>NEMA Design Code</b>	B	<b>KVA Code</b>	L	<b>Starting Current</b>	28.4 A
<b>Service Factor (S.F.)</b>	1.15	<b>No-load Current</b>	2.45 A		
<b>NEMA Nom. Eff.</b>	85.5	<b>Power Factor</b>	71	<b>Line-line Res. @ 25°C</b>	2.89 Ω
<b>Rating - Duty</b>	40C AMB-CONT		<b>Temp. Rise @ Rated Load</b>	36°C	
<b>S.F. Amps</b>			<b>Temp. Rise @ S.F. Load</b>	42°C	
			<b>Locked-rotor Power Factor</b>	54.1	
			<b>Rotor inertia</b>	0.118 LB-FT <sup>2</sup>	

**Load Characteristics 200 V, 60 Hz, 1 HP**

<b>% of Rated Load</b>	<b>25</b>	<b>50</b>	<b>75</b>	<b>100</b>	<b>125</b>	<b>150</b>	<b>S.F.</b>
<b>Power Factor</b>	29	46	60	69	75	80	75
<b>Efficiency</b>	74	83.1	85.3	85.8	85.3	84.4	85.5
<b>Speed</b>	1790	1781	1771	1760	1748	1736	1753
<b>Line amperes</b>	2.54	2.84	3.19	3.65	4.21	4.85	3.86

Performance Graph at 200V, 60Hz, 1.0HP Typical performance - Not guaranteed values

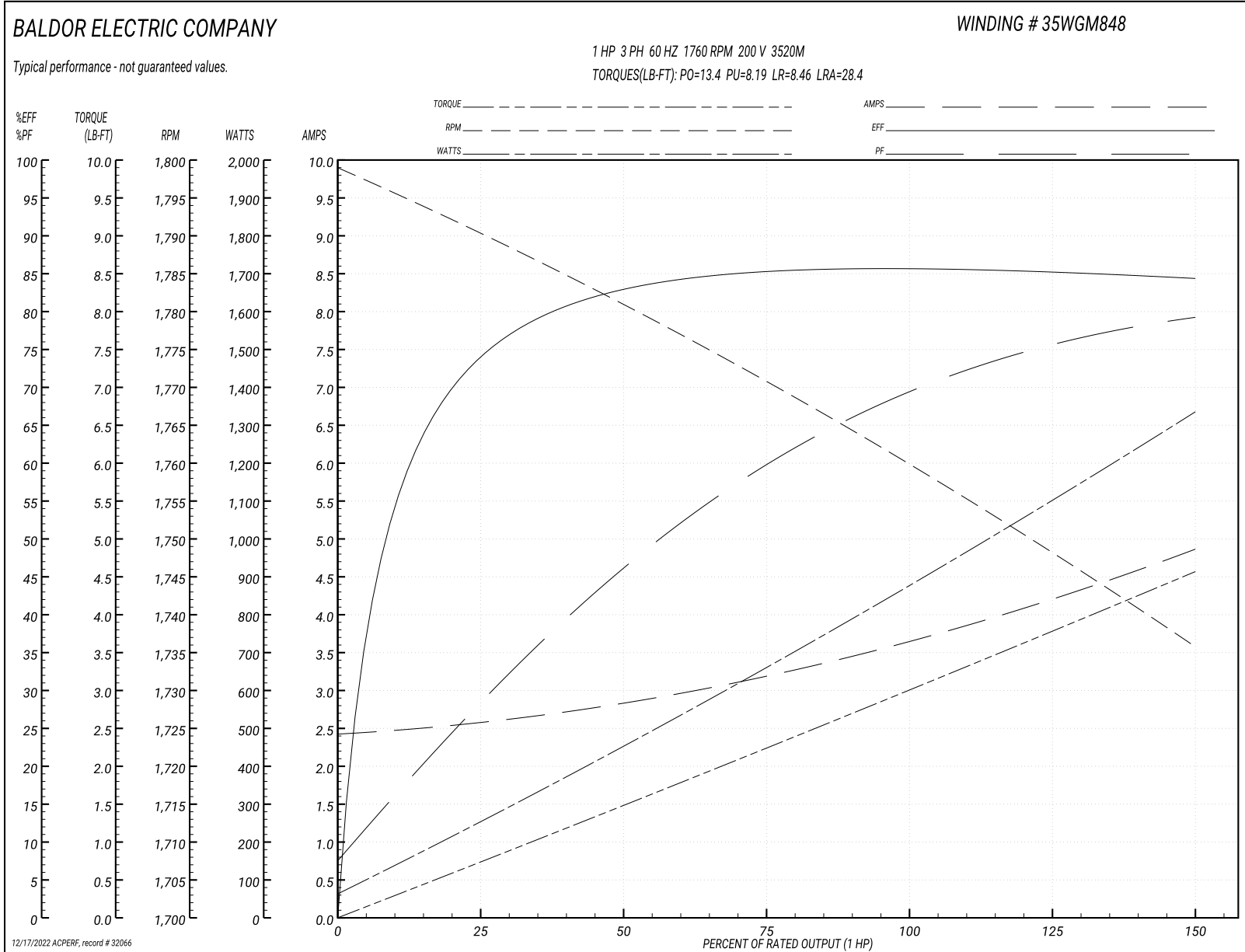

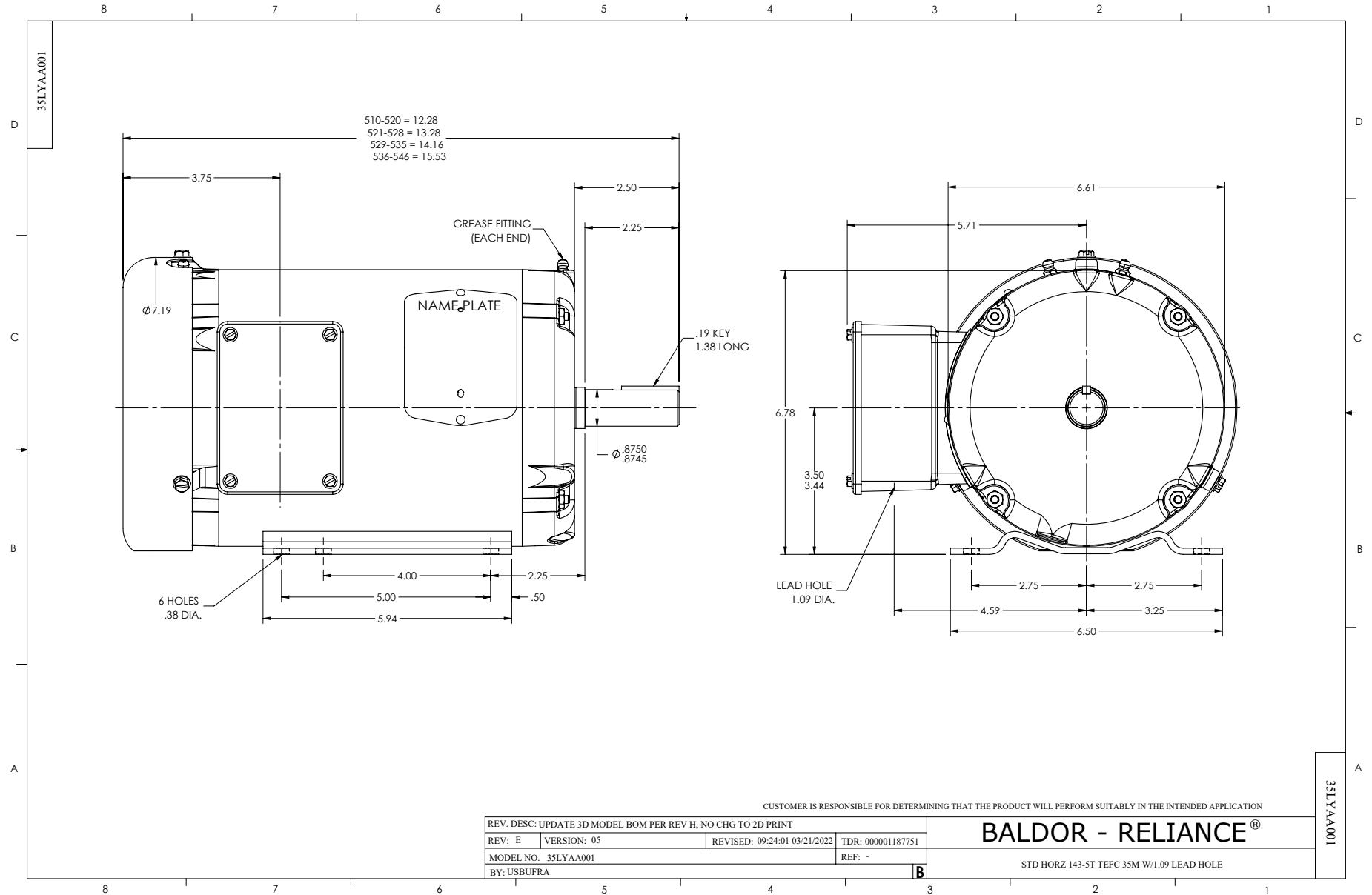

CD0006

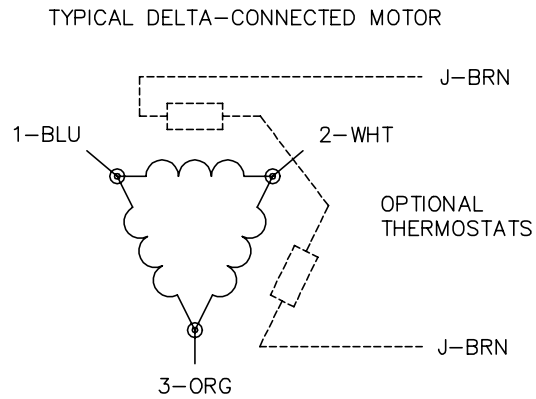
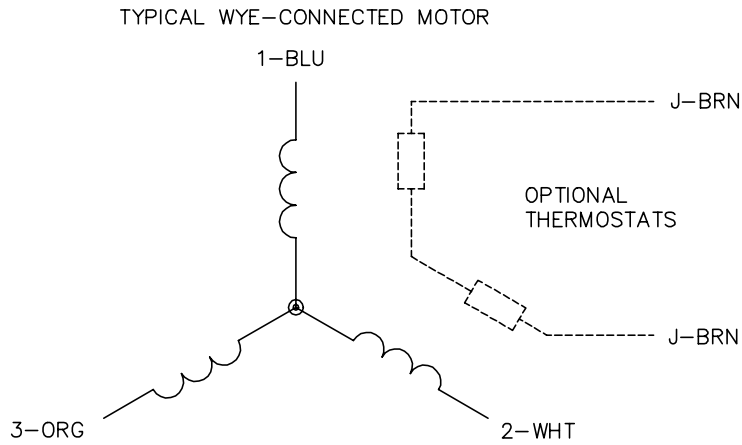

NOTES:

1. THREE LEAD MOTOR MAY BE EITHER WYE CONNECTED OR DELTA CONNECTED.
2. INTERCHANGE ANY TWO LINE LEADS TO REVERSE ROTATION.
3. OPTIONAL THERMOSTATS ARE PROVIDED WHEN SPECIFIED.
4. ACTUAL NUMBER OF INTERNAL PARALLEL CIRCUITS MAY VARY.
5. LEAD COLORS ARE OPTIONAL. LEADS MUST BE NUMBERED AS SHOWN.

CD0006

REV. DESC: ADD CLASS CONN00000007		
REV. LTR: E	VERSION: 01	TDR: 000001099922
FILE: \AAA\00005\141	REVISED: 10:24:49 02/19/2019	BY: ENBRIRO
MTL: -		

**BALDOR - RELIANCE®**

3PH, SV, 3 LEADS, WYE OR DELTA CONNECTED

SH 1 of 1