



Customer information packet

CEM3768T

5HP, 1160RPM, 3PH, 60HZ, 215TC, 0746M, TEFC, F1

ELECTRIC MOTOR WHOLESALE.COM

Class - None

Division - Not Applicable

Specifications

Enclosure	TEFC
Frame	215TC
Frame Material	Iron
Frequency	60.00 Hz
Output @ Frequency	5.000 HP @ 60 HZ
Phase	3
Synchronous Speed @ Frequency	1200 RPM @ 60 HZ
Voltage @ Frequency	460.0 V @ 60 HZ 230.0 V @ 60 HZ
XP Class and Group	None
XP Division	Not Applicable
Agency Approvals	CSA CSA EEV UR
Ambient Temperature	40 °C
Auxillary Box	No Auxillary Box
Auxillary Box Lead Termination	None
Base Indicator	Rigid
Bearing Grease Type	Polyrex EM (-20F +300F)
Blower	None
Current @ Voltage	14.800 A @ 230.0 V 15.300 A @ 208.0 V 7.400 A @ 460.0 V
Design Code	A
Drip Cover	No Drip Cover
Duty Rating	CONT
Efficiency @ 100% Load	89.5 %
Electrically Isolated Bearing	Not Electrically Isolated
Feedback Device	NO FEEDBACK
Front Face Code	Standard
Front Shaft Indicator	None
Heater Indicator	No Heater

Part detail

Revision	L
Type	AC
Mech. spec.	07H058
Base	
Status	PRD/A
Elec. spec.	07WGY763
Layout	07LYH058
Eff. date	07-11-2019
CD Diagram	CD0005
Poles	06
Leads	9#14
Proprietary	False
Created date	06-16-2010

High Voltage Full Load Amps	7.4 a
Insulation Class	F
Inverter Code	Inverter Ready
KVA Code	K
Lifting Lugs	Standard Lifting Lugs
Locked Bearing Indicator	Locked Bearing
Motor Lead Exit	Ko Box
Motor Lead Quantity/Wire Size	9 @ 14 AWG
Motor Lead Termination	Flying Leads
Motor Standards	NEMA
Motor Type	0746M
Mounting Arrangement	F1
Number of Poles	6
Overall Length	19.20 IN
Power Factor	71
Product Family	General Purpose
Pulley End Bearing Type	Ball
Pulley Face Code	C-Face
Pulley Shaft Indicator	Standard
Rodent Screen	None
Service Factor	1.15
Shaft Diameter	1.375 IN
Shaft Extension Location	Pulley End
Shaft Ground Indicator	No Shaft Grounding
Shaft Rotation	Reversible
Shaft Slinger Indicator	No Slinger
Speed	1160 rpm
Speed Code	Single Speed
Starting Method	Direct on line
Thermal Device - Bearing	None
Thermal Device - Winding	None
Vibration Sensor Indicator	No Vibration Sensor
Winding Thermal 1	None
Winding Thermal 2	None

Nameplate

NP3441LUA

CAT.NO.	CEM3768T						
SPEC	07H058Y763G1						
HP	5						
VOLTS	230/460						
AMPS	14.8/7.4						
RPM	1160						
FRAME	215TC	HZ	60	PH	3		
SF	1.15	CODE	K	DES	A	CLASS	F
NEMA NOM. EFF	89.5	PF	71				
RATING	40C AMB-CONT						
CC	010A	USABLE AT 208V				15.3	
ENCL	TEFC	SER					
DE	6307	ODE	6206				
VPWM INVERTER READY							
CT6-60H(10:1)VT3-60H(20:1	50Hz 5HP 190/380V 17.2/8.6A						SF1.0

Parts list

Part number	Description	Quantity
SA198284	SA 07H058Y763G1	1.000 ea
RA185648	RA 07H058Y763G1	1.000 ea
37FN3002C01	EXFN, PLASTIC, 6.00 OD, 1.155 ID	1.000 ea
HW3201A05	3/8-16 EYEBOLT	1.000 ea
09CB3002SP	CB W/1.38 LEAD HOLE FOR 37, 39, 307 & 30	1.000 ea
09GS1000SP	GASKET-CONDUIT BOX, 1/16 THICK LEXIDE	1.000 ea
51XW2520A12	.25-20 X .75, TAPTITE II, HEX WSHR SLTD	2.000 ea
59XW2520G07	.25-20X.44,HEX SER WSHR,TAPTITE 2,GREEN	1.000 ea
37EP1100A41	FR ENDPLATE ASSEMBLY FOR ROUTING	1.000 ea
HW4500A17	317400 ALEMITE GREASE RELIEF	1.000 ea
HW4500A01	1641B(ALEMITE)400 UNIV, GREASE FITT	1.000 ea
HW5100A06	W2420-025 WVY WSHR (WB)	1.000 ea
37PE1300A10	PUEP ASSEMBLY FOR ROUTING	1.000 ea
HW4500A17	317400 ALEMITE GREASE RELIEF	1.000 ea
HW4500A01	1641B(ALEMITE)400 UNIV, GREASE FITT	1.000 ea
10XN2520A30	HEX HD CAP SCREW-STD THD-.25 X 20 THD PE	4.000 ea
HW1001A25	LOCKWASHER 1/4, ZINC PLT .493 OD, .255 I	4.000 ea
XY3118A12	5/16-18 HEX NUT DIRECTIONAL SERRATION	4.000 ea
51XB1214A20	12-14X1.25 HXWSSLD SERTYB	1.000 ea
07FH4007SP	PRIMED	1.000 ea
51XW1032A06	10-32 X .38, TAPTITE II, HEX WSHR SLTD S	3.000 ea
09CB3501SP	CONDUIT BOX LID FOR 09CB3001 & 09CB3002	1.000 ea
09GS1013SP	09 GS FOR 09CB3501 LID - LEXIDE	1.000 ea
51XW2520A12	.25-20 X .75, TAPTITE II, HEX WSHR SLTD	2.000 ea
HW2501F21	KEY, 5/16 SQ X 2.375	1.000 ea
HA7000A02	KEY RETAINER RING, 1 1/8 DIA, 1 3/8 DIA	1.000 ea
85XU0407S04	4X1/4 U DRIVE PIN STAINLESS	2.000 ea
LB1115N	LABEL,LIFTING DEVICE (ON ROLLS)	1.000 ea
MJ1000A02	GREASE, MOBIL POLYREX EM - 124047	0.050 lb
HA3104A32	THRUBOLT- 5/16-18 X12.750	4.000 ea
MG1000Y03	MUNSELL 2.53Y 6.70/ 4.60, GLOSS 20,	0.036 ga

LC0005E01	CONN.DIA./WARNING LABEL (LC0005/LB1119N)	1.000 ea
NP3441LUA	ALUM SUPER-E VPWM INV READY UL CSA-EEV C	1.000 ea
07PA1011	PKG GRP, 07 CAST IRON PK1181	1.000 ea
MN416A01	TAG-INSTAL-MAINT no wire (1200/bx) 3/19	1.000 ea

AC Induction Motor Performance Data

Record # 50558

Typical performance - not guaranteed values

Winding: 07WGY763-R005		Type: 0746M		Enclosure: TEFC	
Nameplate Data			460 V, 60 Hz: High Voltage Connection		
Rated Output (HP)	5	Full Load Torque	22.8 LB-FT		
Volts	230/460	Start Configuration	direct on line		
Full Load Amps	14.8/7.4	Breakdown Torque	81.3 LB-FT		
R.P.M.	1160	Pull-up Torque	49.9 LB-FT		
Hz	60 Phase	3	Locked-rotor Torque	59.9 LB-FT	
NEMA Design Code	A KVA Code	K	Starting Current	54.8 A	
Service Factor (S.F.)	1.15	No-load Current	4.03 A		
NEMA Nom. Eff.	89.5 Power Factor	71	Line-line Res. @ 25°C	1.64 Ω	
Rating - Duty	40C AMB-CONT		Temp. Rise @ Rated Load	50°C	
S.F. Amps			Temp. Rise @ S.F. Load	61°C	
			Locked-rotor Power Factor	22.2	
			Rotor inertia	1.14 LB-FT ²	

Load Characteristics 460 V, 60 Hz, 5 HP

% of Rated Load	25	50	75	100	125	150	S.F.
Power Factor	32	51	63	70	74	76	72
Efficiency	84.9	89.7	90.6	90.4	89.2	87.7	89.7
Speed	1190	1181	1174	1164	1153	1141	1157
Line amperes	4.32	5.06	6.12	7.48	8.92	10.5	8.34

ABB Motors and Mechanical Inc.

WINDING # 07WGY763

Typical performance - not guaranteed values.

5 HP 3 PH 60 HZ 1160 RPM 460 V 0746M

TORQUES (LB-FT): PO=81.3 PU=49.9 LR=59.9 LRA=54.8

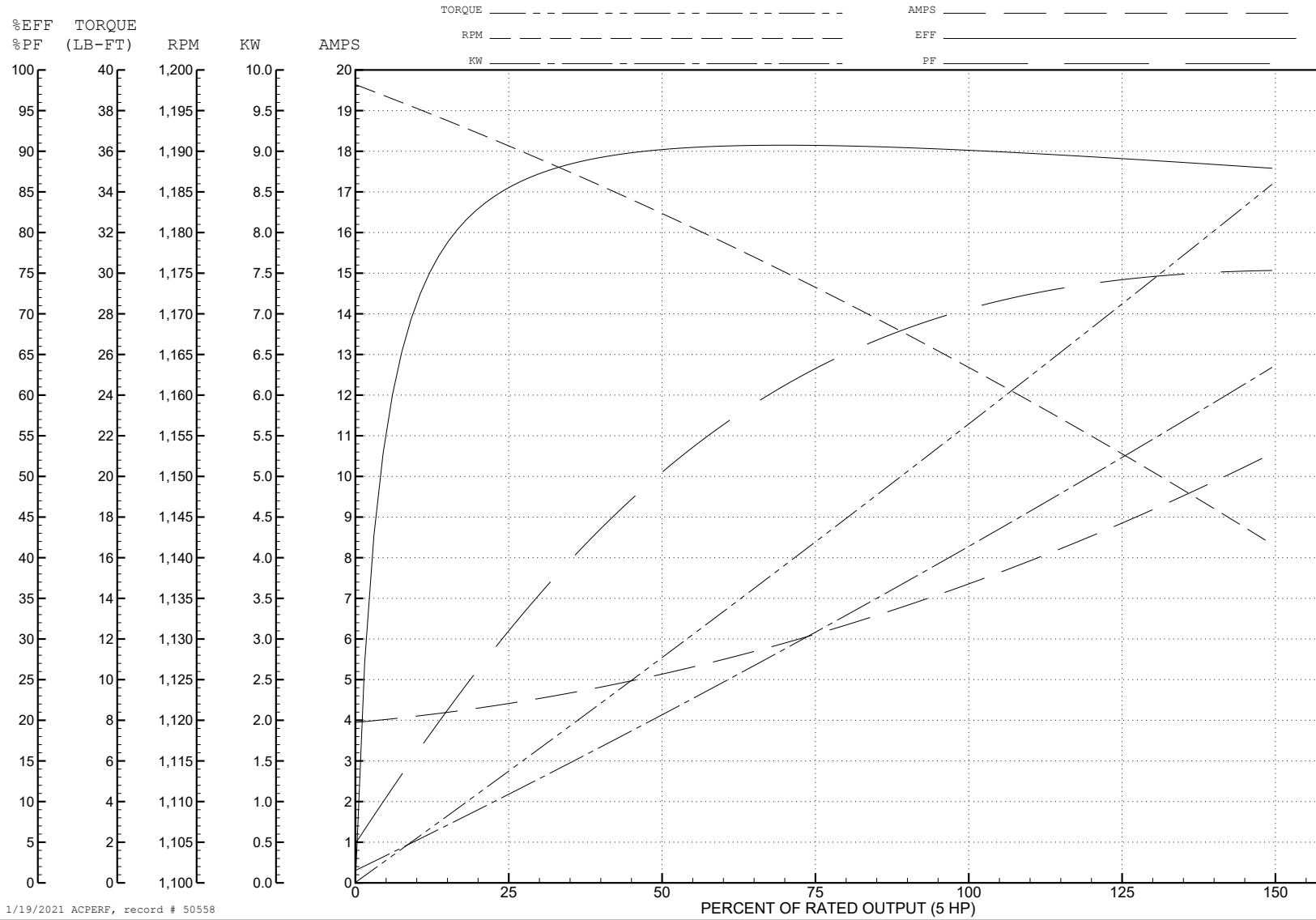

1/19/2021 ACPERF, record # 50558

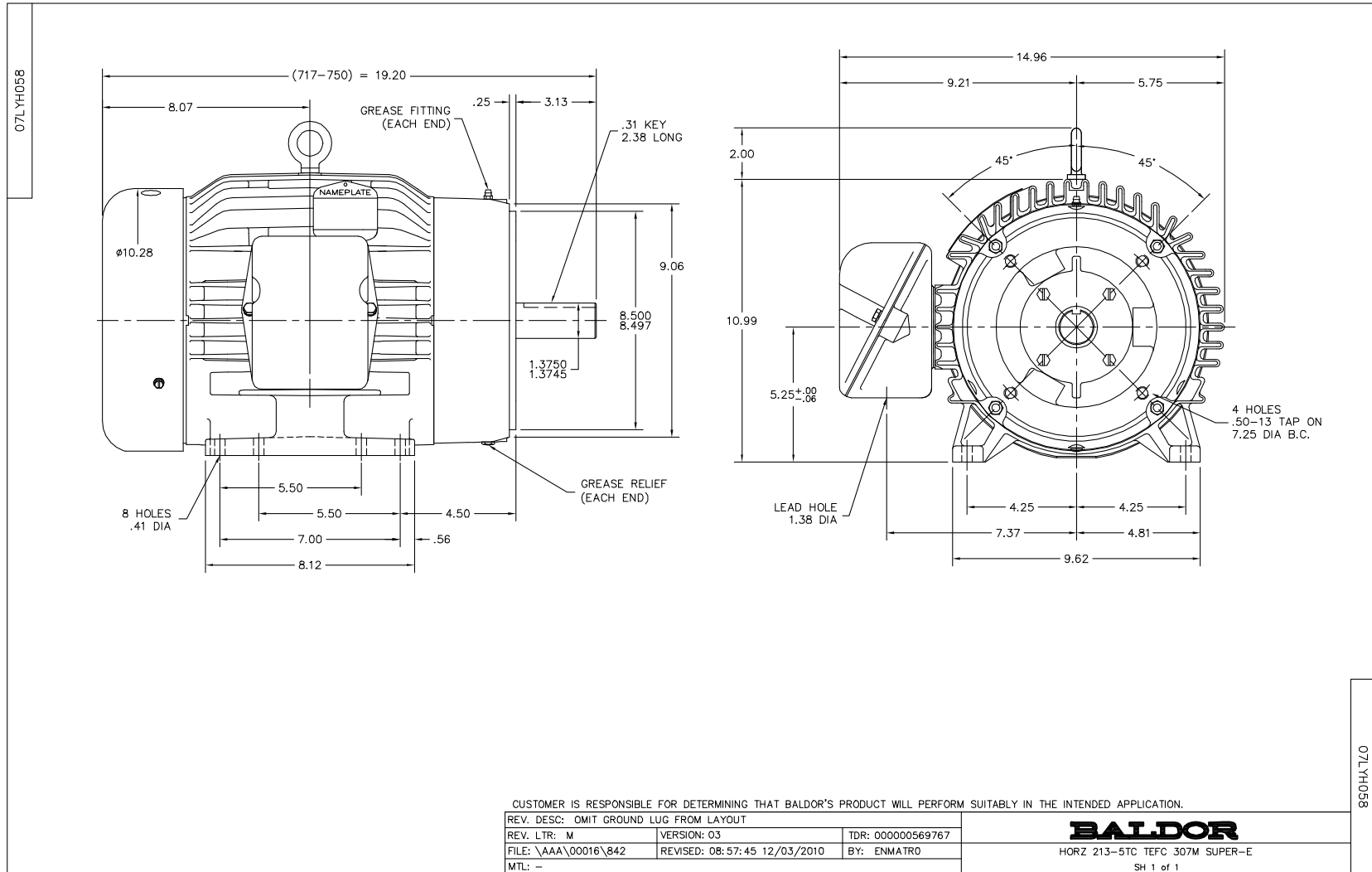

CD0005

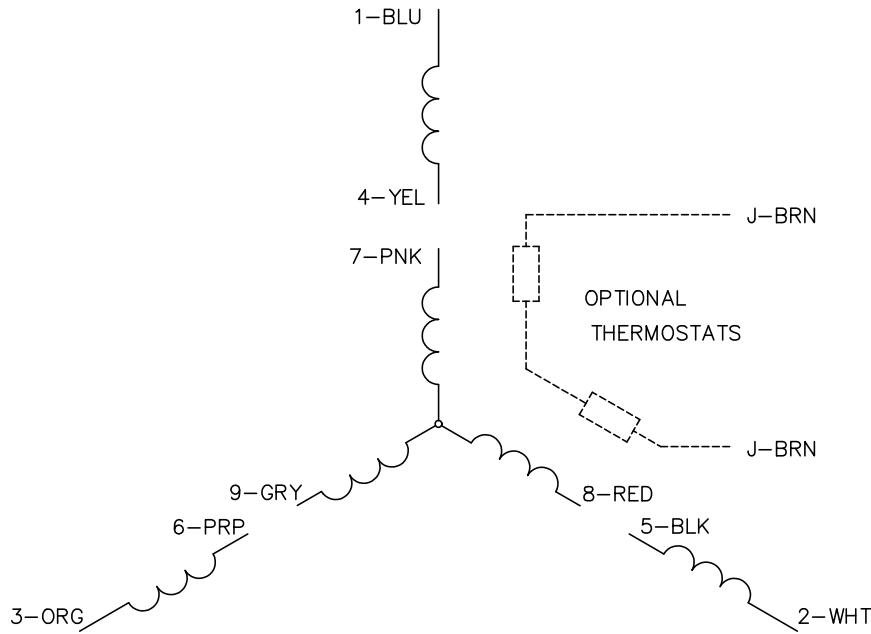

LOW VOLTAGE
(2Y)



LINE

HIGH VOLTAGE
(1Y)



LINE

NOTES:

1. INTERCHANGE ANY TWO LINE LEADS TO REVERSE ROTATION.
2. OPTIONAL THERMOSTATS ARE PROVIDED WHEN SPECIFIED.
3. ACTUAL NUMBER OF INTERNAL PARALLEL CIRCUITS MAY BE A MULTIPLE OF THOSE SHOWN ABOVE.
4. LEAD COLORS ARE OPTIONAL. LEADS MUST ALWAYS BE NUMBERED AS SHOWN.

CD0005

REV. DESC: REVISE TO SHOW OPTIONAL COLORS			
REV. LTR: E	BY: JLP	REVISED: 01/19/99 10:15	TDR: 0171435
S00000		FILE: AAA00005140	MDL: -
		MTL: -	

BALDOR ELECTRIC Co.

3PH, DV, 9 LEADS