

BOTTOM VIEW

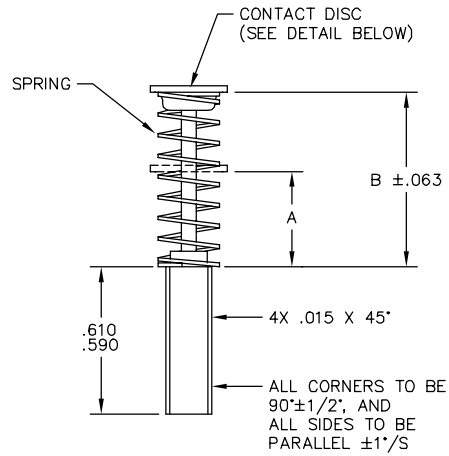

SPRING SPECIFICATIONS	
MATERIAL	= SS302
ACTIVE TURNS	= 28
CLOSED TURNS	= 4(2 EA. END)
FREE LENGTH	= 1.273
SOLID LENGTH	= 0.340
WIRE DIA.	= 0.010
OUTSIDE DIA.	= 0.146
SPRING RATIO	= 0.547
SPRING RATE	= 0.206 LB/IN.
STRESS (MAX.)	= 63,114 PSI

BRUSH WEAR	
A	NEW = .182 LBS. @ .393 IN. ~ 7.50 PSI
B	WORN = .099 LBS. @ .793 IN. ~ 4.10 PSI

SHUNT SPECIFICATIONS	
3 X 22/.002, 264 CMA	

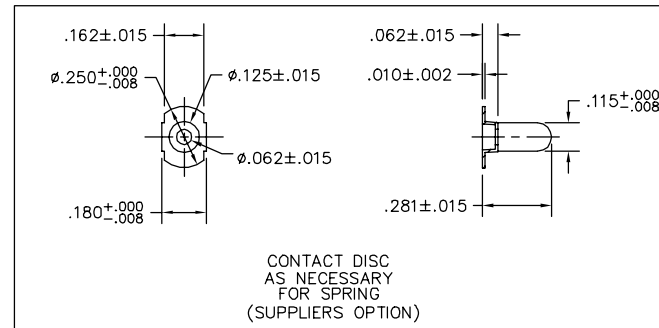

BRUSH ASSEMBLY PART NO.
EXAMPLE: BP5000A01

DWG. NO.	BRUSH GRADE (CODE LETTER)	GROUP NO.
BP5000	SEE FAMILY CODE	01

REV. DESC: UPDATE SHUNT SPEC. PER LY		
REV. LTR: C	VERSION: 02	TDR: 00000966164
FILE: \CKA\00005\175	REVISED: 10:38:20 02/17/2016	BY: CKMICRO
MTL: -		

BALDOR

CARBON BRUSH ASSEMBLY FOR CARTRIDGE TYPE BRUSH HOLDERS

SH 1 of 1